

delta 500 LDR

delta



www.ilapak.com



PACKAGING MACHINERY

TECHNICAL SPECIFICATIONS

Machine speed	Up to 30 cycles per minute in normal use Can be up to 40 cycles, depends on film and product characteristics.
Product dimensions	
LENGTH	Up to 1200mm - 47.2", variable bag length Up to 900mm - 34.5", fixed bag length
WIDTH	300mm - 12" (jaws 345mm - 13.6")
HEIGHT	Up to 200mm - 8.0" standard
Film cut off	Min 100mm - 4" / Max 1000mm - 39.5", fixed bag length Depending on film and product characteristics.
Wrapping materials	Shrink barrier films, laminated, co-extruded and all sealable films
Film reel dimensions	
CORE Ø	76.2mm - 3" standard 152.4mm - 6" on request
OUTER Ø	350mm - 13.8" standard
WIDTH	800mm - 31.5" standard 900mm - 35.4" on request
Film reel max weight	Depending on film reel width, up to 75 kg - 165 lbs
Electronic platform	Industrial PC
Power requirement	From 220 to 480 V, 50/60 Hz, 5kVA
Compressed air	6 bar, 200l/min
Machine weight	1100 Kg - 2400 lbs

MAIN STANDARD FEATURES

Inverted machine with long-dwell sealing head.

3 servo motors to control film/ rollers, jaws head carriage and single belt indexer.

User friendly operator interface with intuitive icons on 6" colour VGA touch screen.

128 programs (additional memory on request)

Automatic product size change.

Integrated temperature control.

Electronic diagnostic on-board.

No product/ no bag.

Misplaced product detection system.

I/O for peripheral units (printer, labelers, gas control, etc.)

Adjustable folding box.

Automatic sealing rollers height adjustment.

Single film reel mounting with self-centering cones, right hand machine version, 2m long infeed including single indexer, standard.

Robust, hygienic, easy to clean design, stainless steel finishing standard.

Please discuss your needs with our local representative to configure these machines to your product's specific requirements.

ILAPAK is ISO 9001:2000 certified

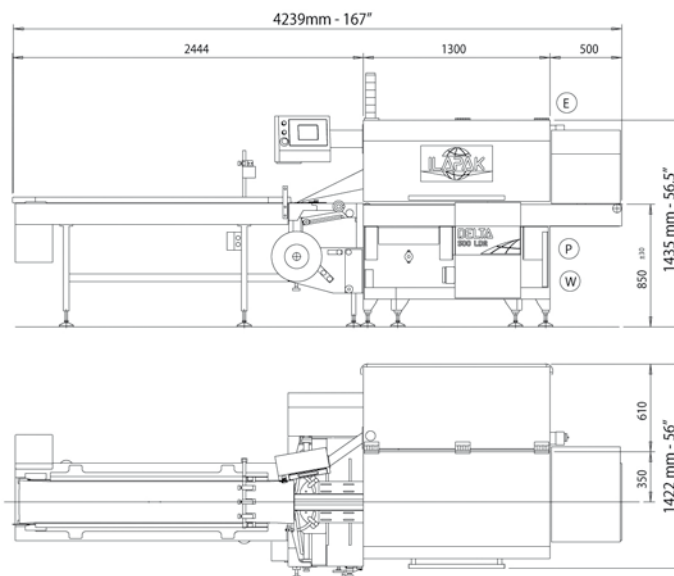

All measurements not specified in inches are given in millimeters.

These specifications are not binding. We reserve that right to change them without prior notice.