



WTS WEIGH TRANSFER SYSTEM



foodmate

Poultry Processing Systems

Designed by Foodmate in collaboration with ChickSort®UK, the WTS Weigh Transfer System boasts speeds in excess of 12000 bph and performs weighing accuracy of ± 10 gram. This new weigh transfer machine offers both speed and accuracy in a simple and compact solution.

Fundamental to the design is a simple but effective transfer mechanism that is easy to set-up and maintain. In addition, the WTS displays a triple load cell weigh head arrangement, which maximizes the weighing time of each bird. Because the weigh heads are stationary, they can be mounted on a separate tower to avoid low frequency vibration from the machine adversely affecting the weighing. Compared to weigh transfer systems from other suppliers, this solution maximizes the weighing "window" without over complicating

the design with revolving electronics, slip rings etc.

The design also avoids the problems associated with existing singlehead and multi-head weighing machines where the loss of one weigh head has a catastrophic effect on production, requiring immediate machine maintenance and down-time. In the unlikely event of a weigh head being lost on this machine, the result is reduced weighing accuracy rather than birds not being weighed at all. Furthermore, as each weigh head is used to measure the weight of every bird, advanced diagnostics allow the automatic detection of weighing problems before they have a negative effect on production.

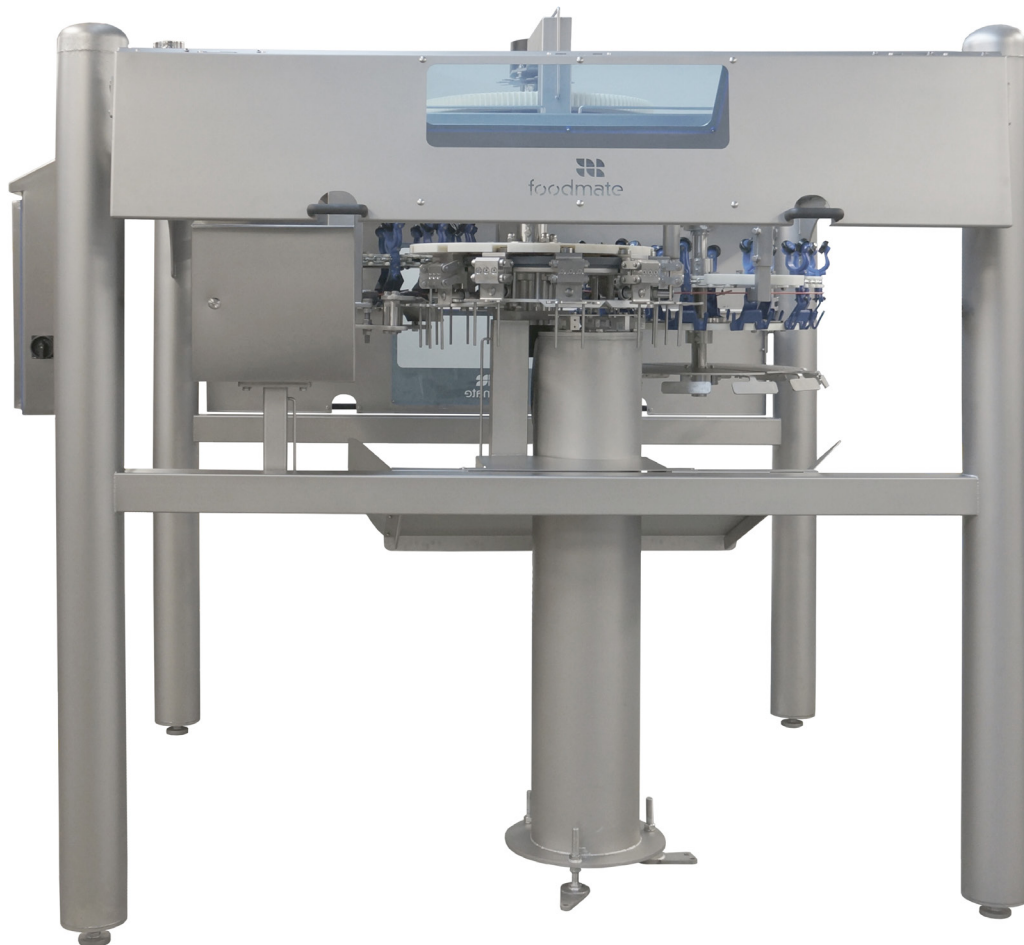

Our mission is to innovate, automate and bring cost-effective solutions to the industry.



WTS WEIGH TRANSFER SYSTEM

Key benefits:

- Speeds in excess of 12000 bph and performs weighing accuracy of ± 10 gram
- Easy set up
- Simple and compact design
- Effective and reliable transfer mechanism
- Automatic detection of weighing problems before they have a negative effect on production
- User friendly
- Easy to maintain and operate

Foodmate is an equipment manufacturing company based in the Netherlands. Founded in 2006, we focus primarily on poultry processing, and we recently launched Foodmate US, expanding our worldwide distribution into North America. Driven by research, paired with unmatched knowledge and decades of experience, it's our mission to innovate, automate and bring cost-effective solutions to the industry.

Our product line spans a wide assortment of processing equipment designed for live bird handling, killing and de-feathering, eviscerating, chilling, weighing, cut-up systems, deboning, and more. In addition to manufacturing, we provide an extensive variety of spare parts and service for other processing equipment and reconditioned machines.

Our team represents decades of industry knowledge and experience resulting in the engineering, development and implementation of new designs for our clients and their ever-changing needs.

Technical Specifications:

- Stainless steel frame and motor
- Line Driven + Sync Control
- Machine dimensions:
 - Length: 2468 mm
 - Width: 2068 mm
 - Height: 2417 mm (Variable)
 - Weight: approx. 1400 kg

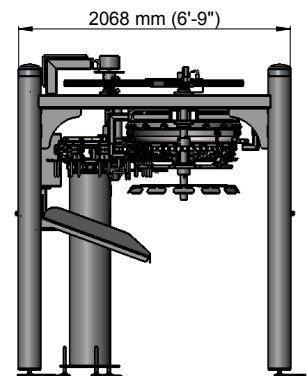
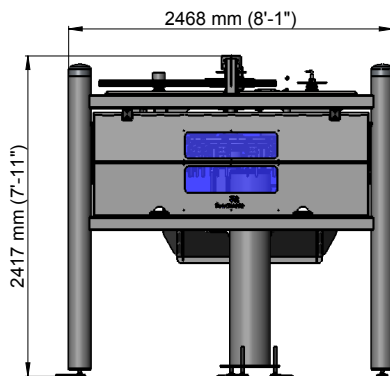

FOODMATE B.V.
 Röntgenstraat 18 • 3261 LK Oud-Beijerland
 P.O. Box 1405 • 3260 AK Oud-Beijerland
 The Netherlands
 Phone: +31-186 630240 • Fax: +31-186 630249
 info@foodmate.nl
 www.foodmate.nl

FOODMATE US, Inc.
 300 Wilbanks Drive, Ball Ground, GA 30107
 P.O. Box 4116, Canton, GA 30114
 U.S.A.
 Phone: +1-678-819-5270 (U.S.) • Fax: +1-678-819-5273
 info@foodmateusa.com
 www.foodmateus.com



foodmate