



# SIGIX M20

## sigilla vaschette thermosealers

- Pratica e robusta sigillavaschette manuale
- Struttura in acciaio inox AISI 304
- Controllo elettronico con temperatura e preriscaldamento
- Conteggio vaschette
- Tempo di saldatura 4 secondi
- Massima dimensione vaschetta mm 260x190
- Stampi custom a disegno
- Piastra sigillante in alluminio teflonato
- Massima larghezza film mm 200.

### Opzionali:

- Vaschette disponibili  
mm 137x95 h.63  
mm 190x137 h.72  
mm 230x190 h.65  
mm 260x190 h.65
- Stampi relativi alle vaschette disponibili.

- A practical and robust manual tray sealer
- AISI 304 stainless steel body
- Electronic controller with temperature and preheating controls
- Tray count
- Sealing time: 4 seconds
- Maximum tray size: 260x190 mm
- Custom dies made to drawings
- Teflon coated aluminium sealing plate
- Maximum film width: 200 mm

### Optionals:

- Standard trays  
137x95, h.63 mm  
190x137, h.72 mm  
230x190, h.65 mm  
260x190, h.65 mm
- Dies for standard tray sizes

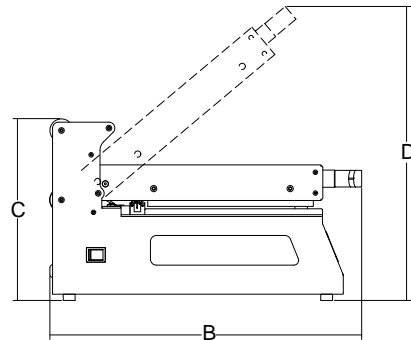
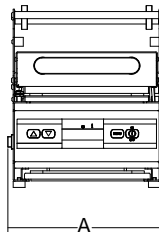

	Potenza Power Spannung Puissance	Alimentazione Power source Betriebsspannung Alimentation	Rotoli film Max. film roll Folienrollen max Max. bobine film	Dimensioni max vaschetta Tray max dimensions Tablets max Abmessungen Dimensions max plateau	A	B	C	D	Peso netto Net weight Nettogewicht Poids net	Dimensioni imballo Shipping Verpack. abmessungen Dim. emballage	Peso lordo Gross weight Bruttogewicht Poids brut
	watt		mm	mm	mm	mm	mm	mm	Kg	mm	kg
<b>Sigix M20</b>	900	230V/50Hz	200	260x190	257	525	306	496	18	620x380x400	22
	Potencia Potência Mощность	Alimentación Alimentação Электропитание	Rollos película Bobina película 最大薄膜卷	Dimensiones máx bandeja Dimensões máx bandeja Лоток Макс размеры 最大托盘尺寸	A	B	C	D	Peso neto Peso líquido Вес нетто 净重	Dimensiones embalaje Dimensões embalagem Размеры упаковки 包装尺寸	Peso bruto Peso bruto Вес брутто 毛重

