

# Oceano

Bottle washer

---

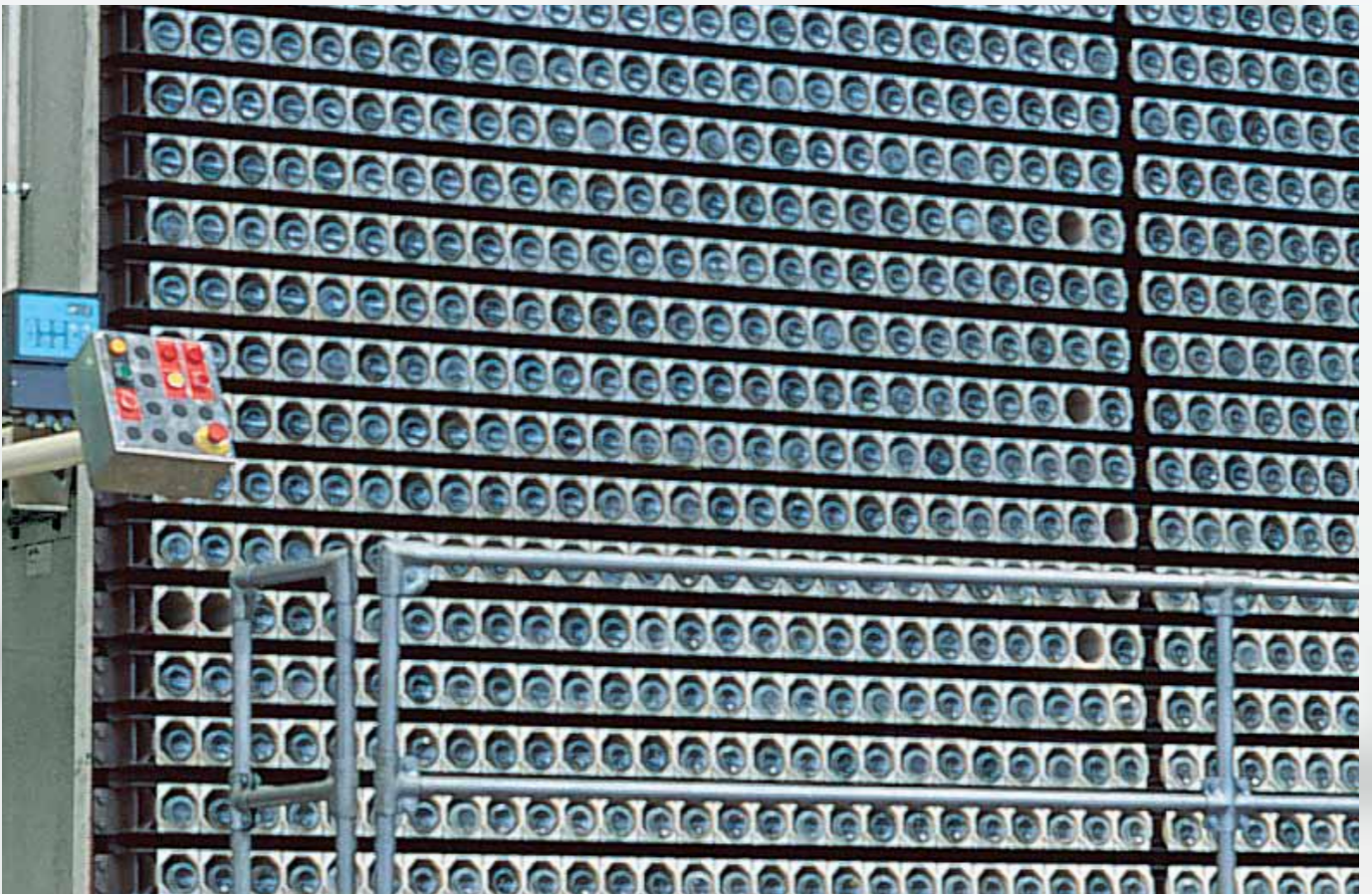



# Oceano

IN THE EFFORT TO REDUCE THE ENVIRONMENTAL IMPACT OF WASTE FROM INDUSTRIAL PRODUCTION, THERE IS AN INCREASINGLY DEEPLY-FELT NEED TO RECOVER EMPTY CONTAINERS, SUCH AS GLASS OR PLASTIC BOTTLES, BOTH IN ADVANCED INDUSTRIAL COUNTRIES AND IN THE DEVELOPING WORLD.

The Oceano bottle washer combines a compact design with functional simplicity. This makes it particularly suitable when space is at a premium and simple working a key factor in choosing a bottle washer.

The fact that Oceano is extended upwards means that, compared to a conventional machine taking up the same floor space, it can offer longer immersion times. Combined with a higher number of sprayings, this guarantees that even particularly dirty bottles are left perfectly clean.



## Washing Cycle

The washing cycle consists of three distinct phases.

**PRE-WASH:** this consists of a zone for emptying residual liquid from the bottles and a zone of jets inside and outside of the bottle. In this zone bottles are pre-heated by the residual heat in the water recycled from the rinse zone.

**WASHING:** a series of tanks contains detergent solution for the actual washing action of the bottles. The number of tanks depends on the treatment time required. The washing operation is effected by means of the chemical action of the detergent solution and the mechanical action of the internal jets situated at the outlet of the detergent soaks. Label removal takes place in this phase.

**RINSING:** there are three internal and external jet zones with recycled water and one with cold water. The gradual lowering of the temperature and the removal of the detergent solution are obtained as the water flows in the opposite direction to the bottles, thus considerably reducing the amount of fresh water used. The rinse water is then used in the pre-wash area; from here part of it can also be used to feed the crate washer.

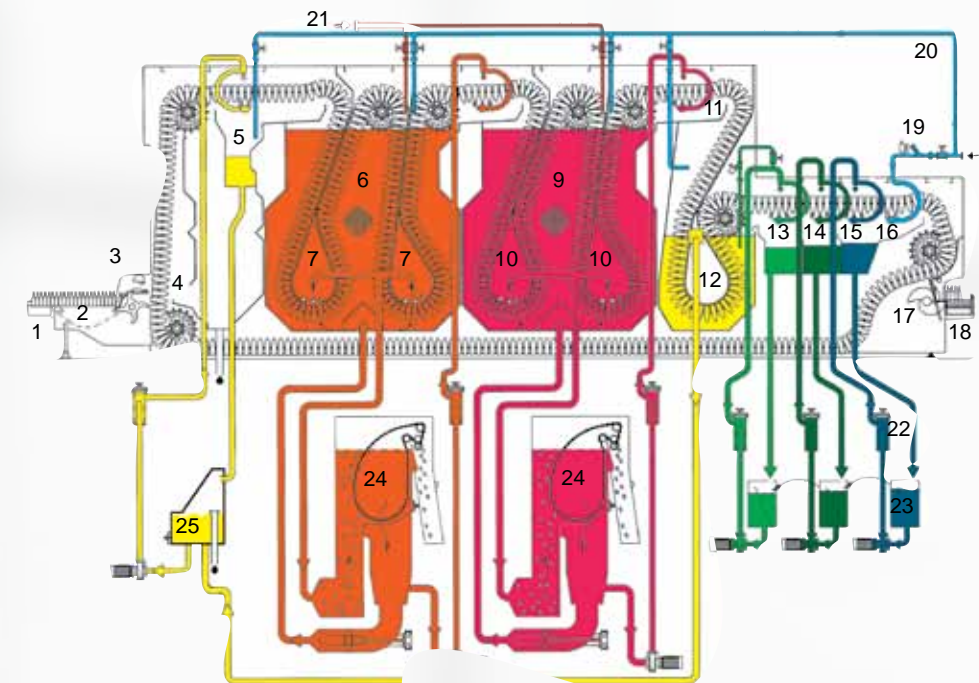

- |  |                                   |                                    |
|--|-----------------------------------|------------------------------------|
| 1. bottle feed conveyor                      | 9. second detergent soak at 80°C. | 18. bottle discharge conveyor      |
| 2. accumulation table                        | 10. label extraction zone         | 19. fresh water infeed             |
| 3. bottle loading                            | 11. detergent jets at 80°C.       | 20. tank water intake              |
| 4. residual liquid emptying                  | 12. rinse soak at 60°C.           | 21. liquid detergent inlet         |
| 5. pre-wash jets at 40°C. (single or double) | 13. 1st rinse jets at 48°C.       | 22. static tubular filter          |
| 6. 1st detergent soak at 70°C.               | 14. 2nd rinse jets at 35°C.       | 23. static sluice gate filter      |
| 7. label extraction zone                     | 15. 3rd rinse jets at 28°C.       | 24. label extraction filter        |
| 8. detergent jets at 70°C.                   | 16. fresh water jets at 20°C.     | 25. self-cleaning parabolic filter |
|  | 17. bottle discharge section      |                                    |



# Loading system

The conveyor belt of the accumulation table conveys the bottles to the automatic loading system, dividing them into separate rows by means of agitators on the table.

The bottles are pushed inside the carrier pockets by two separate synchronized continuous rotating movements: the first introducer takes the bottle from the accumulation table and sets it horizontally on the slides; the second pushes the bottle into the pocket. Safety devices are fitted on both movements to stop the machine in cases of overloading. The alarm signal is visualized on the operator control panel. The bottle separators on the accumulation table are made of plastic material and allow for quick format changeover, if necessary.

The bottle loading motion is transmitted from the main drive, while the accumulation table has an independent gearmotor worked by electric signal directly by the introducer shaft in order to adjust to the speed of the machine. The table stops for an instant when the first introducer grips the bottle in order to reduce the pressure from the other bottles.

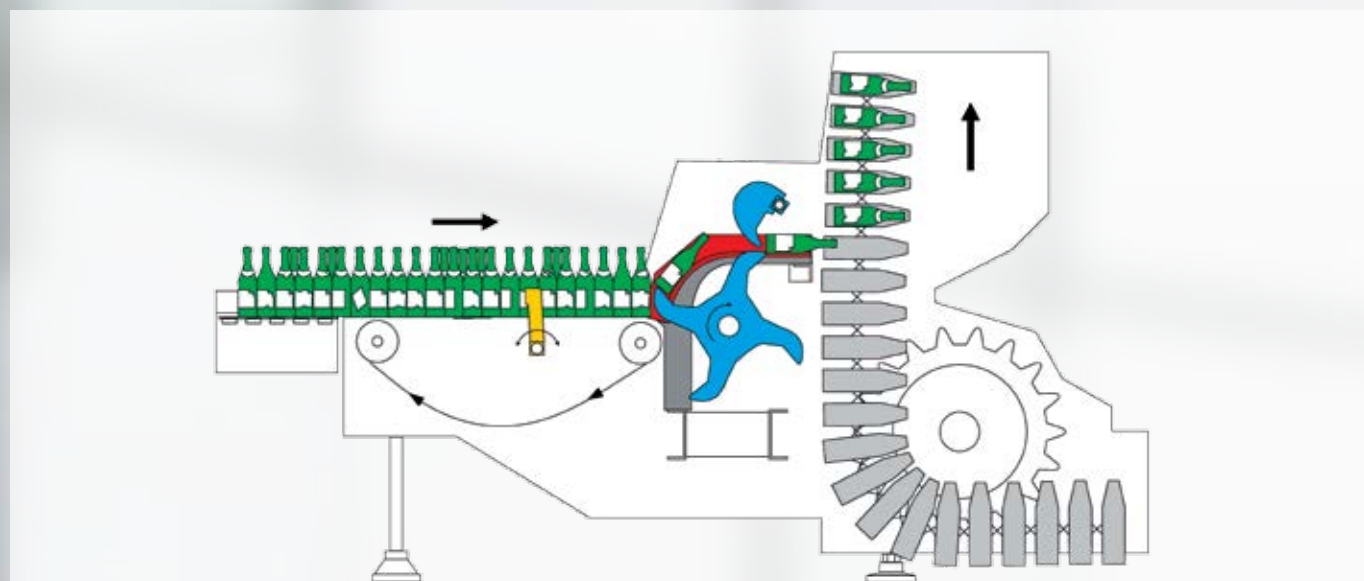

# Discharge system

The bottle slides down a plastic chute onto a mobile plate. At the right moment, the plate rotates so that the bottle drops onto a cam which accompanies it to the discharge conveyor. This cam thus accompanies the bottle in its falling motion, shifting the bottle previously discharged towards the discharge conveyor. All parts in contact with the bottles are made of plastic in order to reduce noise.

Three safety systems are used: the first controls the removal of the bottle from the pocket by means of a sensor monitoring the position of the chutes; the second checks the movement of the cams by means of a clutch fitted on the cam support shaft; and the third monitors the obstruction of the conveyor by means of a barrier rod fitted at the end of the discharge conveyor.

The bottle separators on the accumulation table and the chutes permit quick format changeovers if necessary. The system is driven by the main chain drive gearmotor through an angular transmission connected by a chain.

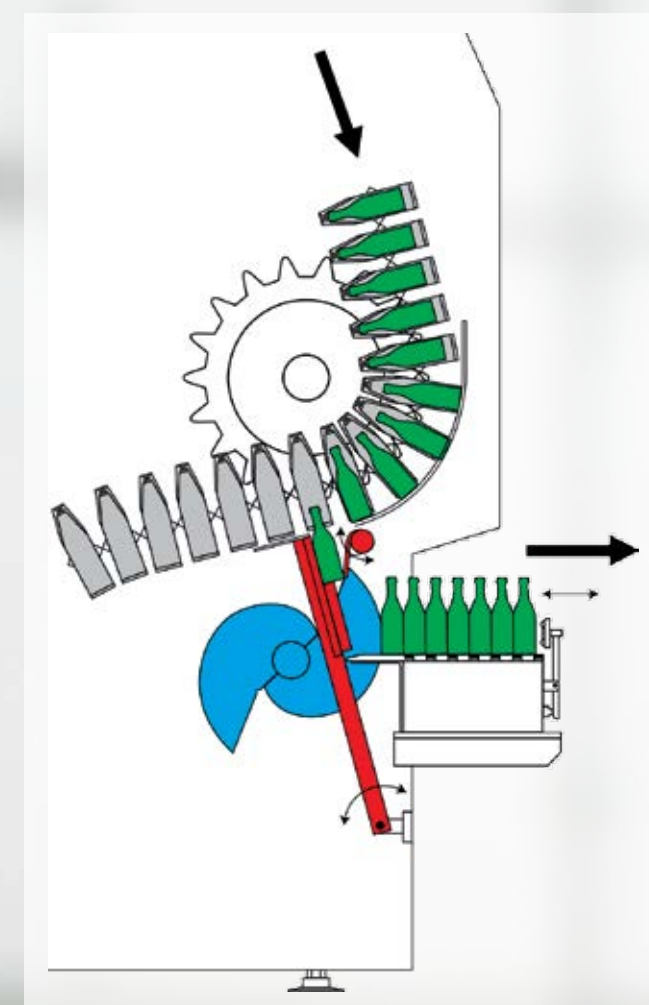



# Self-cleaning rotary jetters

The spray jet follows the bottle in a rotary motion given by the bottle carrier beams by means of a plate (an integral part of the beam) and by a starwheel (an integral part of the spray). The spray, as it moves, covers the entire bottle surface. The self-cleaning effect is due to the continuous rotation of the spray nozzles, allowing water to flow in two directions. The spray nozzle is held in position by intermediate supports.

Maintenance operations can be carried out simply by removing the supports to gain direct access to the underlying secondary supports, without losing the timing with the bottle. Moreover, the system is not affected by lengthening the chain.

An alternating jet system is also available.

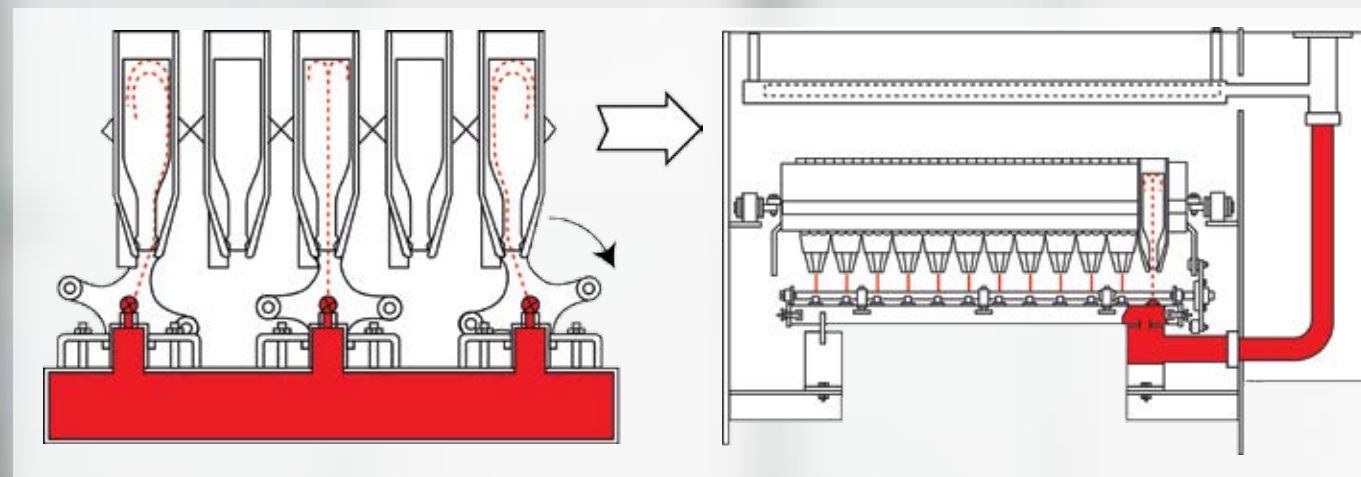

# Label extraction

The basis for efficient label removal and extraction is a combination of chemical and mechanical actions. The pump sucks the detergent solution from the filter and sends it into the tank: the flow passes through the carrier pockets and detaches the label from the bottle.

The detergent solution carries the label into the wire-mesh filter, which then extracts it from the machine by means of a counter-rotating brush.

All the mechanisms for the wire mesh movement and the pump are positioned outside the washer in order to make periodical maintenance easier. The mesh and brush are driven by a motor-variator and geared motors. The flow created by the pump prevents the labels from settling at the bottom of the tanks, and allows the label to be removed without any damage, if of good quality. The detergent solution is mixed in such a way that there are no differences in temperature and concentration inside the tank.

The capacity of the pump may be varied by changing the drives to adapt the system to the various working conditions.

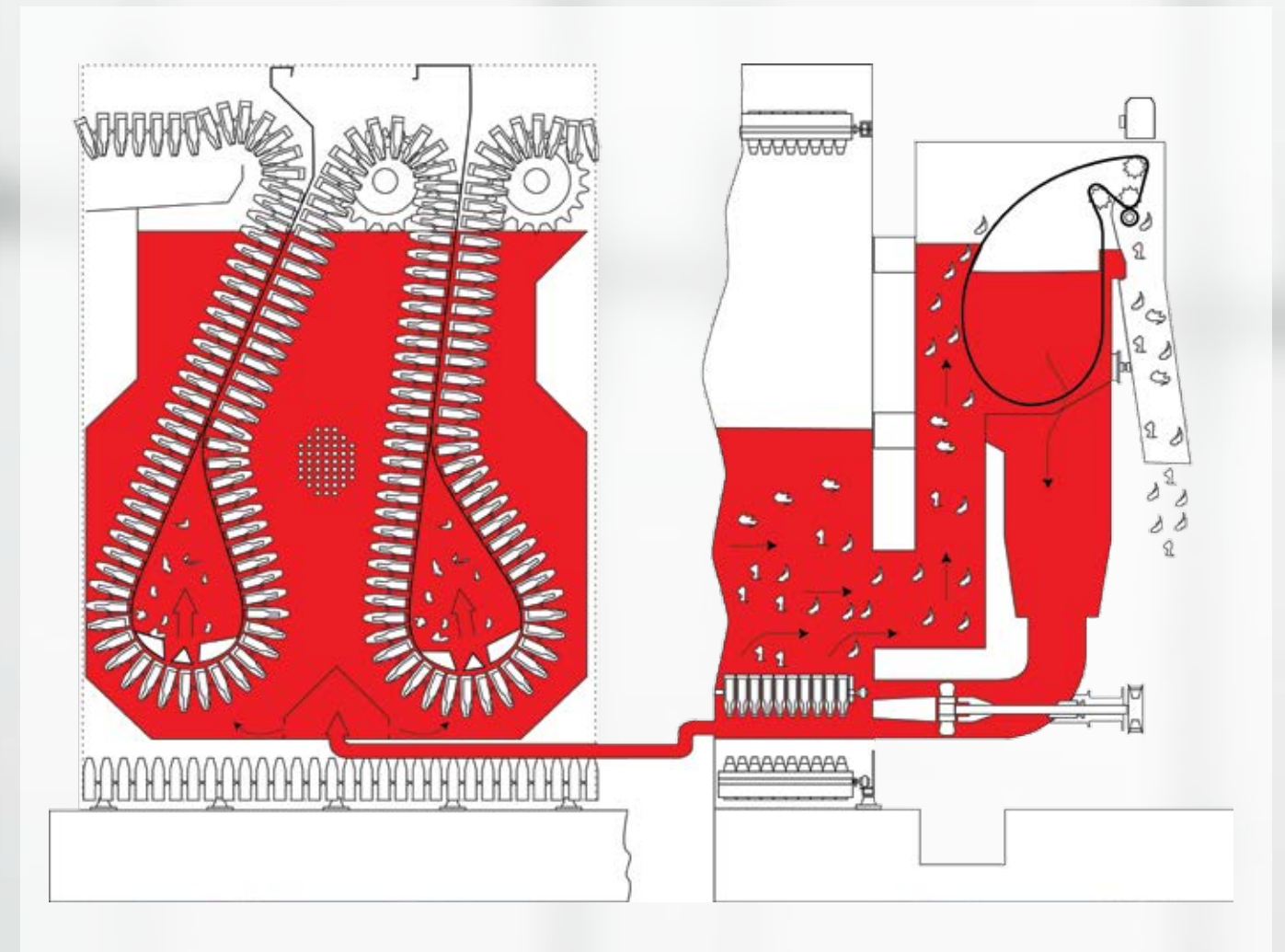



# Drive

The movement of the main chain is driven by an electric motor controlled by a frequency variator.

The gearbox is fitted with mechanical and heat safety devices which are activated in the event of irregularities or overloads.

Production speed may be varied manually from the operator panel. The movement is transmitted by means of cardanic shafts and chains to the worm reduction units positioned on the main shafts. All the gears are equipped with mechanical safety devices.

The shafts are supported on one side by the gearbox and on the other side by a sleeve in special material. The toothed wheels are bolted to the shaft so that they can be dismantled for maintenance. The Oceano bottle washers may be equipped with an electronic axis (optional).

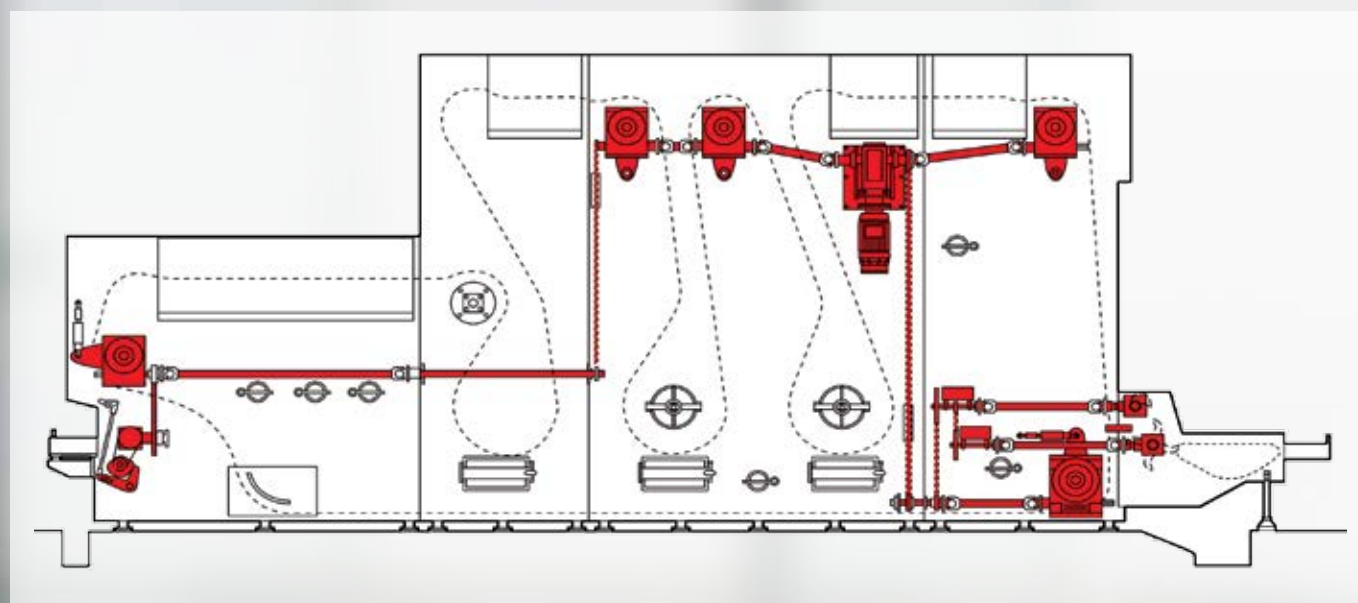

# Bottle transport

The bottles are conveyed in plastic pockets. The special design of the pockets makes the label extraction easier, ensures that the bottle is centered under the jetting stations, and protects the bottle. Within certain limits, the pockets can take varying bottle sizes and shapes, without however, any change in their functional features. The pockets are fitted into the pocket-carrying beam and are easily removed and replaced. The beam is made of mild steel. The special design has enabled us to obtain high characteristics of torsional and flexural stiffness, and also avoid carrying over detergent solution. The chain is made of low-alloy, hardened, tempered steels guaranteeing high levels of endurance and strength.

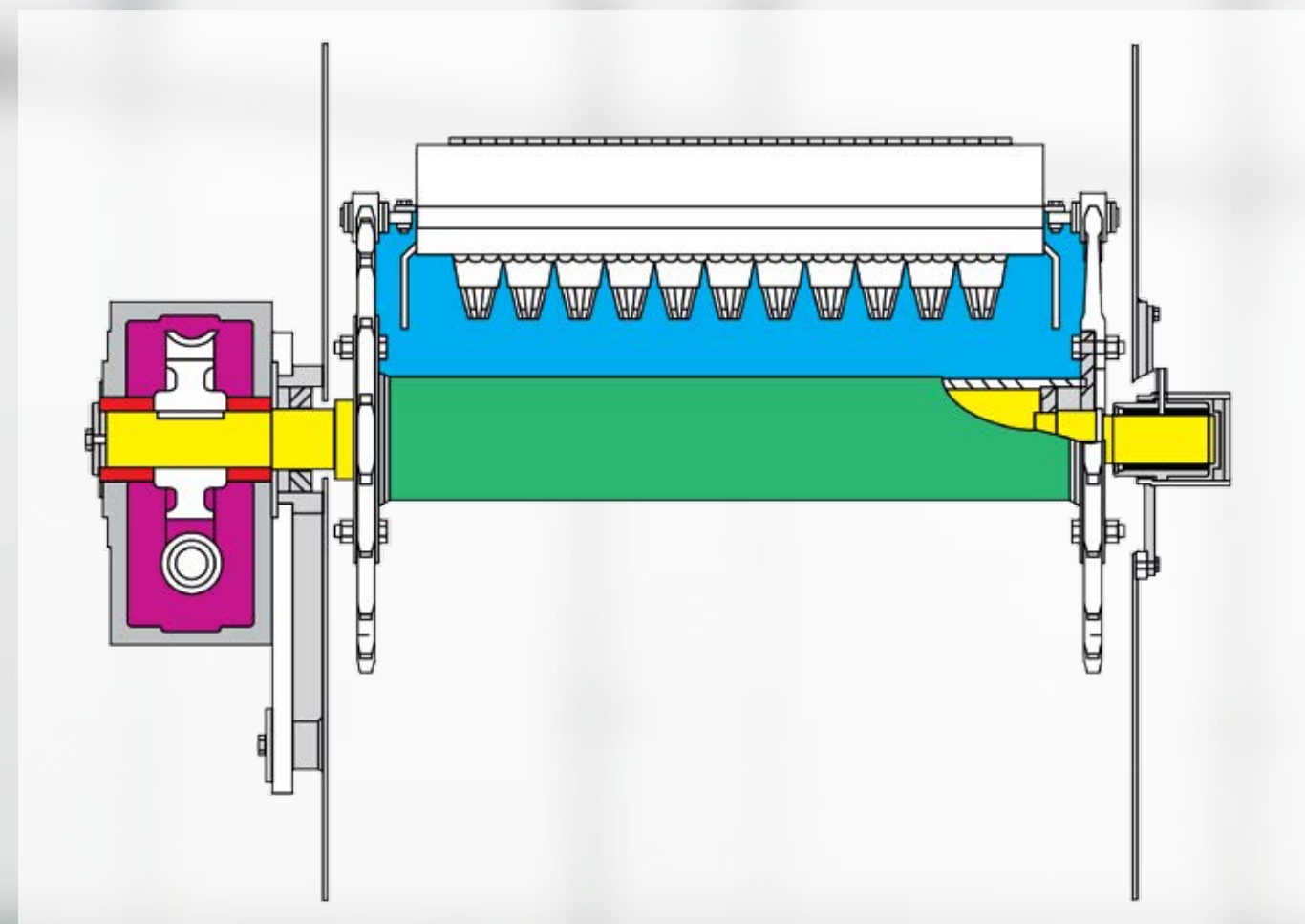



# Service

## STEAM:

each detergent tank is fitted with an independent heating system controlled by a PID instrument on the operator panel. Saturated steam at 4 bar is required. The condensate is collected in a single pipe system.

## MAINS WATER:

the system feeds the jets for the final rinse: the pressure is controlled by a pressure switch, which indicates any pressure drop and stops the machine. The bottles leaving the washer will have the same microbiological properties as the water used in the final rinse.

## DETERGENT:

the system allows the manual feeding of the detergent tanks with liquid soda with a maximum concentration of 40%.

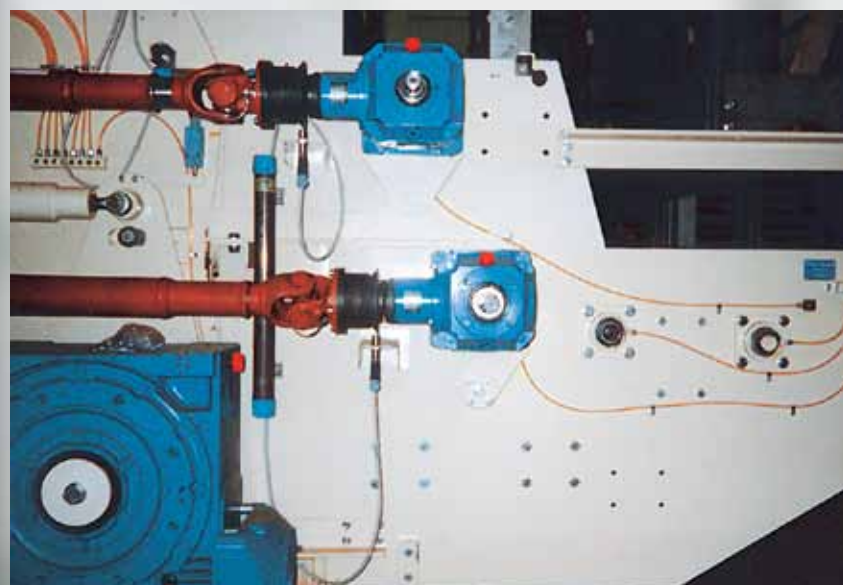

## ADDITIVES:

the bottle washer is preset for the installation of additive dosing equipment in the detergent tanks and the rinse section.

## AIR:

the system is fitted with a treatment unit and pressure reducing unit. The connections are made with flexible plastic pipes and quick release fittings.

## LUBRIFICATION:

the lubrication points are clustered in rilsan pipework for user-friendly access. The rotating points of the cardan shafts are not connected to the lubrication system.



# Electrics and operator interface

The electrical system is built in accordance with current European regulations. All machine functions are controlled by a PLC.

All the components are housed in the main panel, while the machine operation controls are located in the console near the operator station, on the infeed side. The main operator panel is a PC-based operator interface showing all information about process parameters and failures.

The main advantages of this solution are:

- An operator-friendly interface
- A data acquisition system integrated in the interface
- The possibility of remote connection for diagnostics or updating purposes.

A button board is positioned in the unloading area and, in addition to start and stop controls, it also contains signaling from the bottle unloading safety devices. The electrical cables, connecting the panels to users, are routed through channels (either galvanized and painted or, upon request, in stainless steel) located on the machine roof and sides. All cables and electrical components are properly codified to facilitate identification.

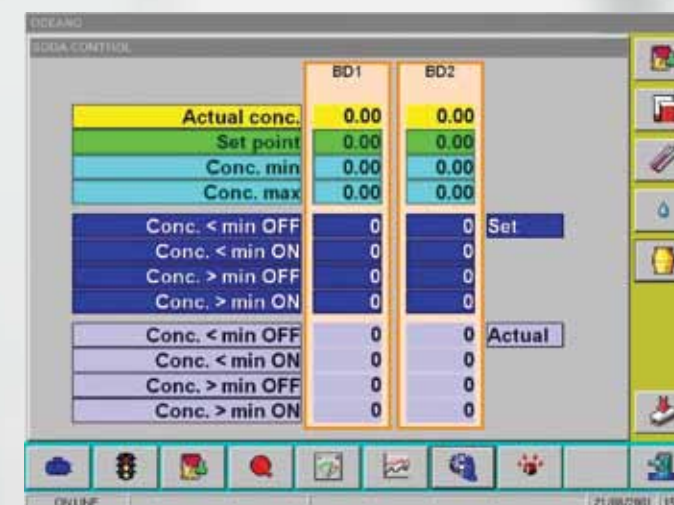
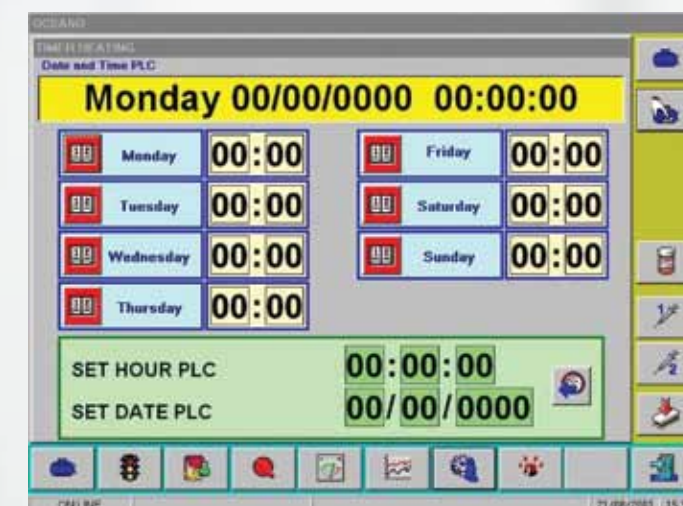

# First in line

---

In a complex industry where know-how is everything, Gebo Cermex is formed from the union of two strong brands: Gebo & Cermex, gathering packaging line engineering experience across a range of market segments from beverages and food to pharmaceuticals, via home and personal care.

For over half a century, our experts have improved the performance of production and packaging lines in some of the most demanding industries.

Today **more than 37,000 equipment & systems installations bear our signature**. We add value to our customers' business in four dimensions, from equipment design and manufacturing to line engineering, services and asset performance.

Gebo Cermex, headquartered in Strasbourg, France is a people-centric organization with **1800 employees and over 20 commercial & manufacturing sites** in all major regions around the world.

**No-one knows packaging lines like we do. We are first in line.**

**Gebo Packaging Solutions Italy**  
Via della Elettronica, 9 • 37139 Verona - Italy  
Tel.: +39 045 8399411

**Gebo Cermex Headquarters**  
Rue du Commerce, CS 73455 Reichstett • 67455 Mundolsheim Cedex - France  
Tel.: +33 (0)3 88 18 38 50

■ [contact.us@geboacermex.com](mailto:contact.us@geboacermex.com) ■ [www.geboacermex.com](http://www.geboacermex.com)



**GEBO**