



## OPTI XL LEG PROCESSOR



**foodmate**

Poultry Processing Systems

The new Foodmate OPTI XL Leg Processor is specifically designed to help maximize bone-in and boneless dark meat yields. The machine gives a high yield anatomical cut and good meat and skin presentation. The machine can accommodate a wide size range while maintaining a high percentage of “white knuckles” and minimal bone content with minimal to no adjustments.

The OPTI XL Leg Processor is specifically designed to handle so called “big birds” or large chickens. The machine has more room inside the machine to accommodate a large chicken and mechanically self-adjusts for each bird size. The OPTI XL Leg Processors can be installed in either a new Foodmate Cut Up System or it can easily be integrated into existing frame or flex type cut up system.

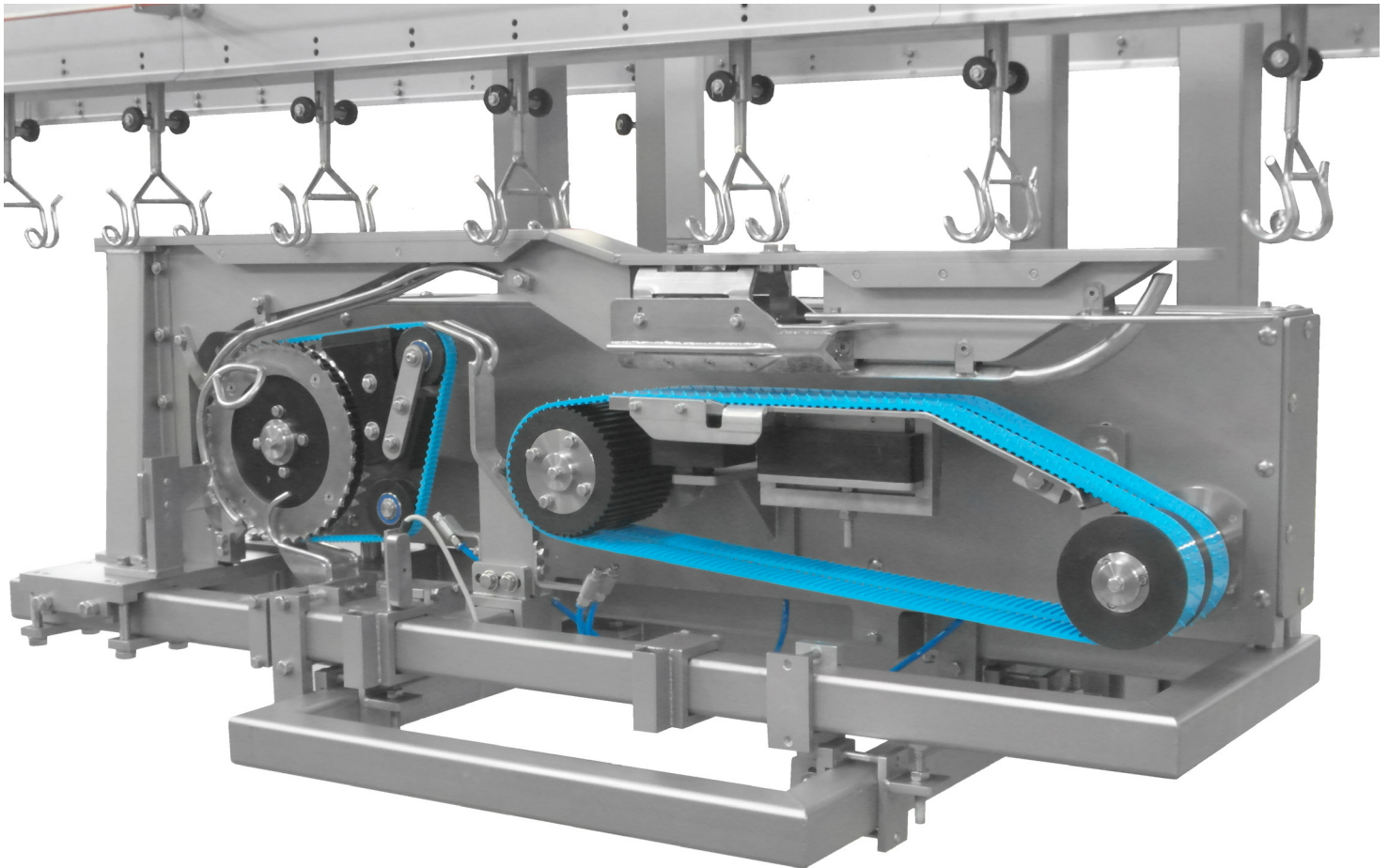

Our mission is to innovate, automate and bring cost-effective solutions to the industry.



## OPTI XL LEG PROCESSOR

### Key Benefits:

- Increases flexibility by accommodating a wide size range
- High Yield
- Low bone content
- High percentage of "white knuckles"
- Integrates into existing frame or flex type cut up systems
- Very heavy duty and durable design
- User friendly – only requires minor adjustments

Foodmate is an equipment manufacturing company based in the Netherlands. Founded in 2006, we focus primarily on poultry processing, and we recently launched Foodmate US, expanding our worldwide distribution into North America. Driven by research, paired with unmatched knowledge and decades of experience, it's our mission to innovate, automate and bring cost-effective solutions to the industry.

Our product line spans a wide assortment of processing equipment designed for live bird handling, killing and de-feathering, eviscerating, chilling, weighing, cut-up systems, deboning, and more. In addition to manufacturing, we provide an extensive variety of spare parts and service for other processing equipment and reconditioned machines.

Our team represents decades of industry knowledge and experience resulting in the engineering, development and implementation of new designs for our clients and their ever-changing needs.

### Technical Specifications:

- Stainless steel frame and motor
- Motor (IP66) power is 0,75 kW
- Machine dimensions:
  - Length: 1672 mm
  - Width: 1058 mm
  - Height: 2182 mm (Variable)
  - Weight: approx. 400 kg

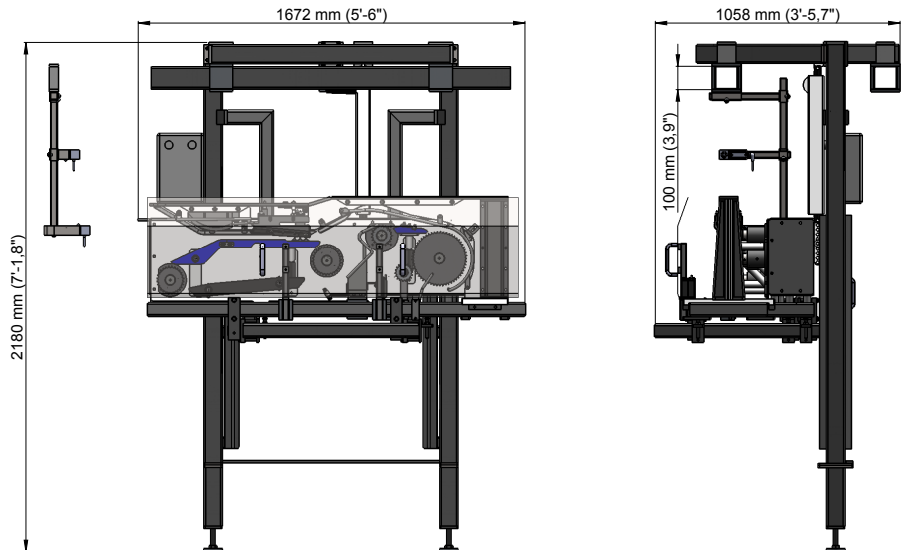

FOODMATE B.V.  
Röntgenstraat 18 • 3261 LK Oud-Beijerland  
P.O. Box 1405 • 3260 AK Oud-Beijerland  
The Netherlands  
Phone: +31-186 630240 • Fax: +31-186 630249  
info@foodmate.nl  
www.foodmate.nl

FOODMATE US, Inc.  
300 Wilbanks Drive, Ball Ground, GA 30107  
P.O. Box 4116, Canton, GA 30114  
U.S.A.  
Phone: +1-678-819-5270 (U.S.) • Fax: +1-678-819-5273  
info@foodmateusa.com  
www.foodmateus.com



foodmate