

# CARRERA 500



[www.ilapak.com](http://www.ilapak.com)



PACKAGING MACHINERY

## TECHNICAL SPECIFICATIONS

<b>Machine speed</b>	Up to 100 cpm, single jaw. Up to 200 cpm, twin jaws 150mm - 5.9"centre. Production output dependent upon product, film and machine specifications.
<b>Product dimensions</b>	
LENGTH	50/550 mm - 2/21.6" with any jaws centres and length
WIDTH	20/230mm - 0.8/9" with jaw length 250mm - 9.8" 20/300mm - 0.8/11.8" with jaw length 325mm - 12.8"
HEIGHT	Up to 90mm - 3.5" with jaw centre 150mm - 5.9" Up to 120mm - 4.7" with jaw centre 180mm - 7.1"
<b>Film cut-off</b>	Up to 630mm - 24.8" Cut-off defined as: product length+height+40mm (1.6"), depending on product characteristics.
<b>Wrapping materials</b>	Suitable heat-sealable films, such as plain, or co-extruded polypropylene (PP), laminate films (e.g. OPP+PE), as well as cold sealable films of suitable quality
<b>Film reel dimensions</b>	
CORE Ø	76mm - 3"
OUTER Ø	350mm - 13.8"
WIDTH	650mm - 25.6"
<b>Film reel max weight</b>	40 kg - 88 lbs
<b>Electronic platform</b>	PLC Controlled machine.
<b>Power requirement</b>	From 220 to 480V, 50/60 Hz, 3-phase, 5kVA
<b>Compressed air</b>	6 bar, 1l/min with air gusseting
<b>Machine weight</b>	850 kg - 1874 lbs

## MAIN STANDARD FEATURES

PLC-controlled HFFS machine with rotary sealing jaws.

Multi-axis drive technology with 3 independent drive circuits consisting of an AC motor controlled by a frequency inverter for product infeed, sealing rollers and rotary sealing jaws.

A simple-to-use operator interface TFT touch screen display, 5,7" wide, 64.000 colours, allows quick product change-over

99 program memory; Additional user-defined password level for limiting access to selected machine functions. Service mode for diagnostics, trouble shooting and basic machine configuration

Automatic adjustment of film-pull, infeed and sealing parameters during product or program change.

Precision temperature control circuits ensure seal strength and quality.

No product/ no bag.

Single piece transparent guarding with safety interlock.

Robust mechanical construction with welded sheet metal main body, epoxy powder coating or (opt.) stainless-steel finishing.

Hygienic design with cantilevered body and infeed, for easy clean down.

Single film reel mounting with self-centering cones, right hand machine version, 2,5 m long infeed, standard.

Three pre-defined, plus two user defined electronic cam outputs for peripheral devices

SD flash memory slot for download / upgrade product and machine parameters; SD card contains full operating system.

Please discuss your needs with our local representative to configure these machines to your product's specific requirements.

ILAPAK is ISO 9001:2000 certified

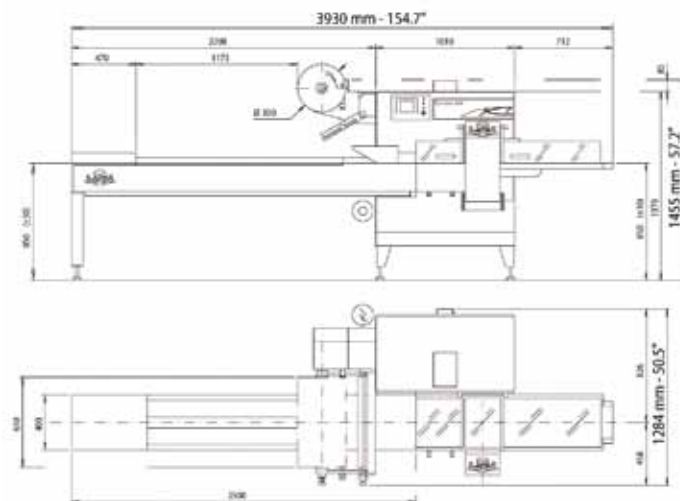

All measurements not specified in inches are given in millimeters.

These specifications are not binding. We reserve that right to change them without prior notice.