



## AUTOMATIC NECK BREAKER



**foodmate**

Poultry Processing Systems

The Foodmate Automatic Neck Breaker is utilized to break the neck at the breast side of the product, in various types of poultry. Each unit is capable of breaking the neck and stripping it off the bird with the neck skin attached to the product. This machine has its own collection tray and wiper to ensure the necks are unloaded at one location. The Neck Breaker is fitted with 16 breaking units and a drum with position mechanisms

to locate a correct position prior to actual neck breaking. It also allows for adjustable infeed timing and height adjustment for various weight ranges. The machine needs to be hooked up to the main water supply to clean each breaker unit after each cycle. It is stainless steel and food approved nylon constructed and is driven by the overhead conveyor system.

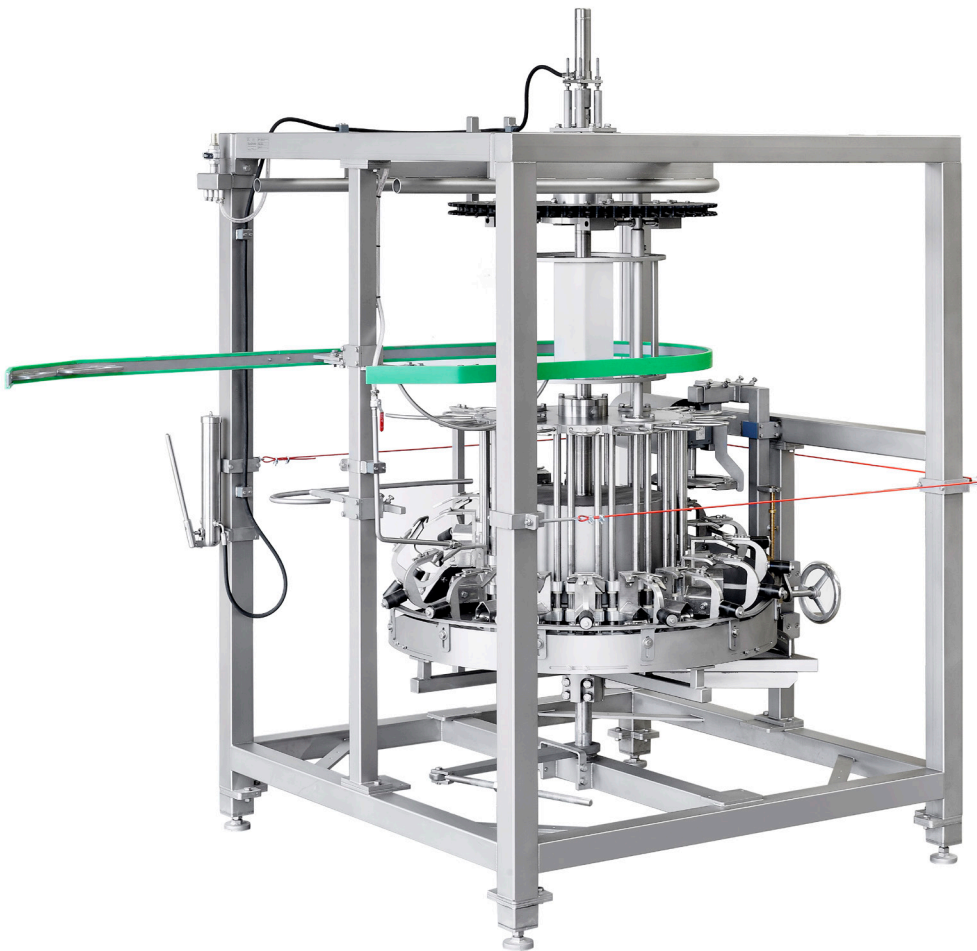

Our mission is to innovate, automate and bring cost-effective solutions to the industry.



## AUTOMATIC NECK BREAKER

### Key Benefits:

- Allows for a maximum of 9,000 birds per hour

Foodmate is an equipment manufacturing company based in the Netherlands. Founded in 2006, we focus primarily on poultry processing, and we recently launched Foodmate US, expanding our worldwide distribution into North America. Driven by research, paired with unmatched knowledge and decades of experience, it's our mission to innovate, automate and bring cost-effective solutions to the industry.

Our product line spans a wide assortment of processing equipment designed for live bird handling, killing and de-feathering, eviscerating, chilling, weighing, cut-up systems, deboning, and more. In addition to manufacturing, we provide an extensive variety of spare parts and service for other processing equipment and reconditioned machines.

Our team represents decades of industry knowledge and experience resulting in the engineering, development and implementation of new designs for our clients and their ever-changing needs.

### Technical Specifications:

- Stainless steel frame
- Units: 16
- Pitch: 6" or 8"
- Rotation: CW/CCW
- Conveyor type:
  - Pipe
  - T-track
- Machine dimensions:
  - Length: 2676 mm
  - Width: 1600 mm
  - Height: 2649 mm
  - Weight: approx. 775 kg

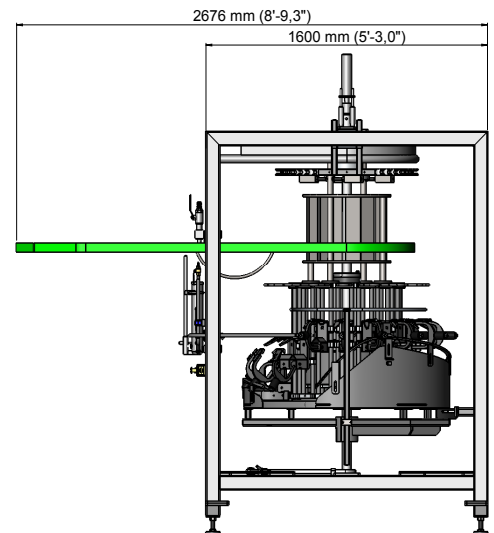
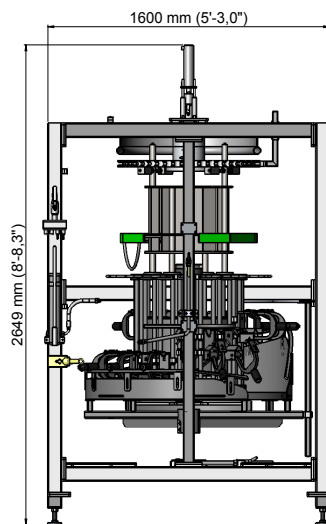

FOODMATE B.V.  
Röntgenstraat 18 • 3261 LK Oud-Beijerland  
P.O. Box 1405 • 3260 AK Oud-Beijerland  
The Netherlands  
Phone: +31-186 630240 • Fax: +31-186630249  
info@foodmate.nl  
www.foodmate.nl

FOODMATE US, Inc.  
300 Wilbanks Drive, Ball Ground, GA 30107  
P.O. Box 4116, Canton, GA 30114  
U.S.A.  
Phone: +1-678-819-5270 (U.S.) • Fax: +1-678-819-5273  
info@foodmateusa.com  
www.foodmateus.com



foodmate