

## Reliability is no coincidence

Our ultra-modern CNC-machines ensure exact dimensional accuracy of all components and a perfect and hygienic surface of the machine parts. Our product choice and workmanship stand for the long life of our stuffers. After the piston reaches the top or bottom position, the machine changes to a function of depressurized oil circulation.

This method prevents the oil from warming up. Due to the closed oil circulation the oil remains free from impurities.



## Services

Services are nowadays more and more important. The reliability of our demonstrators and technicians stands for the high quality of FREY products.

Our stuffers are well-thought out even in the smallest details. They are well-known for their long service life.

## Ergonomic operation

The total height of only one meter provides a comfortable working.

Thanks to the operating bar both hands are free to hold the casing, even bigger diameters can quickly be filled.

The operating bar can be adapted to each body height.

Due to the compact dimensions KOMPAKTA 2 finds room everywhere.

## Cleaning and hygiene

An easy cleaning is the basic requirement for best hygienic conditions in the production. The expenditure for cleaning and maintenance is very low due to the easy disassembling and neat contours between the parts.

- ⑩ Machine base and housing are made of solid stainless steel.
- ⑩ The filling cylinder is made of solid stainless steel with a wear resistant coating.
- ⑩ The sausage piston is made of a high-quality plastic material and is easy in weight and maintenance.

Heinrich Frey  
Maschinenbau GmbH

Fischerstraße 20  
D-89542 Herbrechtingen  
Germany

Phone: +49 73 24 / 172 0  
Fax: +49 73 24 / 172 44

Internet: [www.frey-online.com](http://www.frey-online.com)  
Email: [info@frey-online.com](mailto:info@frey-online.com)

FREY piston  
stufers:

O20

MF 30-4

K2 30 C60H

K2 30 LCD3



# OSCAR 20 - the classic

Oscar has been constructed under the nowadays motto: smaller, quicker, cheaper. The 20-liters-stuffer is completely made of high quality stainless steel and fulfills the strict security and hygiene demands of the CE-standard specification. Oscar is mobile and can be used wherever the stuffer is required for your production.

Besides the classic sausage production Oscar 20 is often used for the production of delicatessen food.

Therefore multiple accessories are available.

Smooth external contours allow a quick cleaning.

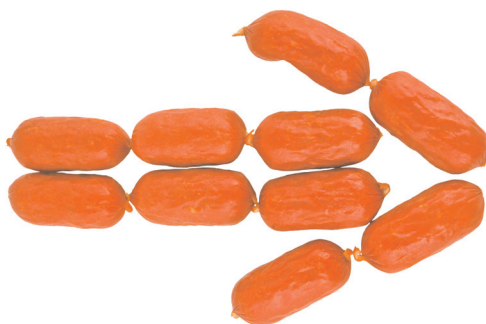
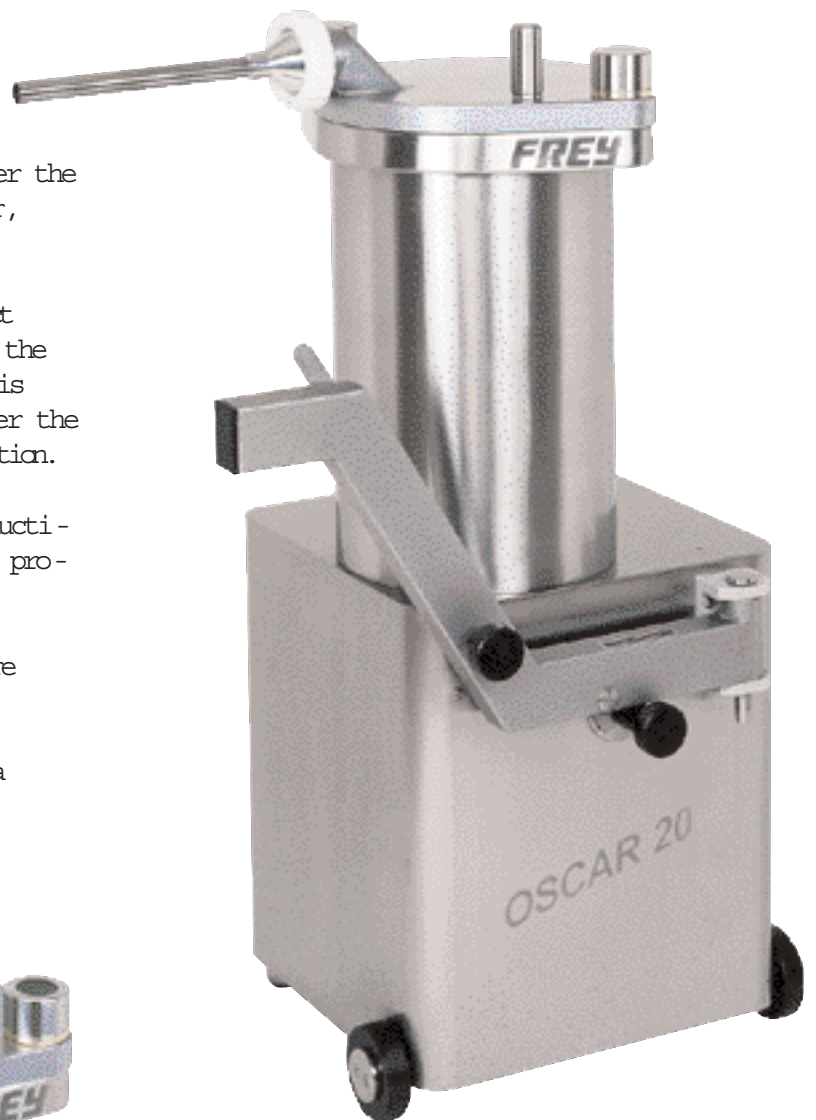

## Technology

The adjustable oil circulation ensures an immediate flow of the sausage meat after operating the operating bar.

This means

- ⑩ no air bubbles
- ⑩ no last-runnings

⑩ Hygienic design of the smooth cylinder bottom with rinsing water outlet made of stainless steel.

⑩ The cover is completely made of solid stainless steel with a handy quick closing.

⑩ OSCAR ensures longevity with little service. The maintenance costs of OSCAR per year are below 1% of the purchase price.

# Powerful, practical and conforming to CE- standard

## Customer advantages

- ⑩ Only little leftovers due to the special cover outlet.
- ⑩ The short and wide form of the outlet guarantees the best possible quality.
- ⑩ Quick change of filling tubes.
- ⑩ The multi-functional operating bar enables a comfortable working at the filling desk. All functions of OSCAR can completely be controlled with the operating bar, e.g. start and stop, speed or return of the piston.
- ⑩ The filling speed is infinitely variable.
- ⑩ Solid construction of cylinder and cover.



## Technical data of OSCAR 20

Capacity of the filling cylinder: 20 liters  
Automatic pressure release.  
Regulation infinitely variable

Voltage: 230/400 V, 50 Hz  
Connected load: 0,75 kW, 1400 turns/min.  
Filling cylinder, piston, cover, housing: solid stainless steel  
Weight: 130 kg

Accessories:  
Filling tubes 12, 20 IH, 30 mm  
Closing nut  
Piston extractor

## Optional:

Foot drive for the production of antipasti products

Special tubes for the production of delicatessen products like sheep cheese into olives, red peppers and tomatoes.

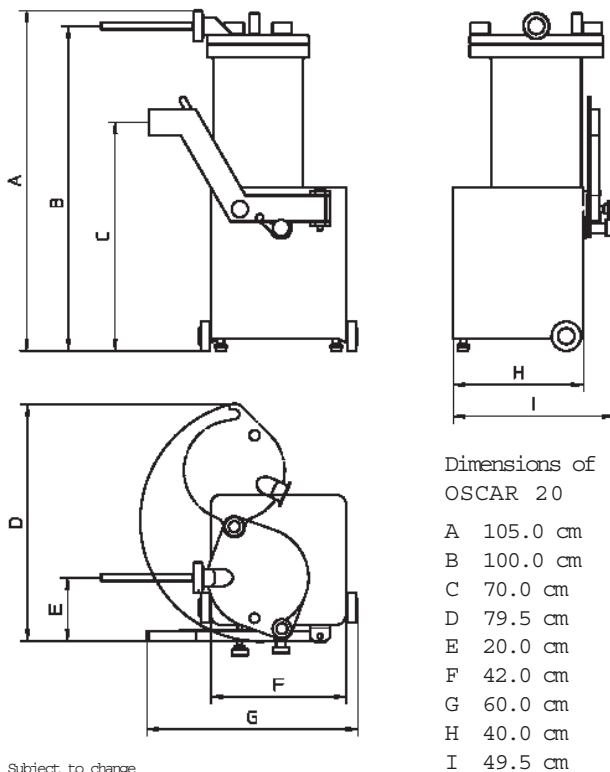

Subject to change



# MF 30-4

## The robust 30-liters-piston stuffer

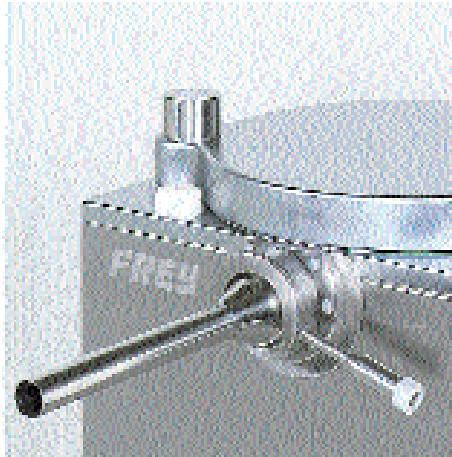

MF 30-4 is actually the ne plus ultra among the 30-liters-piston stuffers regarding workmanship and quality.

MF 30-4 has been constructed and manufactured conforming to the strict security and hygienic demands of the CE-standard specifications.

Machine support, piston, cylinder, cover and operating bar are made of high-quality stainless steel.

Smooth external contours enable a quick and easy cleaning.

### Quick change of sorts

With the swivelling cover and due to the large dimensions of the cylinder the machine can easily be opened for charging.

The sealing of the piston prevents the sticking of the product to the cylinder wall. The machine can immediately be recharged.



### Technology

A variable oil circulation ensures an immediate flow of the product after operating the operating bar.

This means

- ⑩ no air bubbles
- ⑩ no last runnings

Hygienic form of the smooth cylinder bottom with rinsing water outlet and round connection with the cylinder wall.

MF 30-4 ensures a long service life with little maintenance.

The maintenance costs of MF 30-4 per year are below 1% of the purchase price.

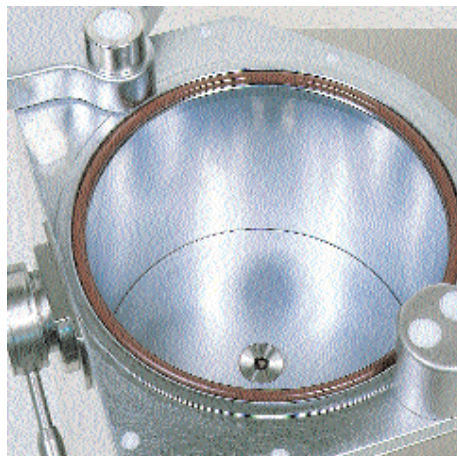

# Customer advantages

- ⑩ Unproblematic filling even of critical products like e.g. Salami, due to the high filling pressure.
- ⑩ Only little left overs due to the direct outlet.
- ⑩ The short and amply dimensioned outlet guarantees the best possible quality.
- ⑩ Quick change of filling tubes.
- ⑩ The multi-functional operating bar enables a comfortable working at the filling desk. All functions of MF 30-4 can completely be controlled with the operating bar, e.g. start and stop, speed or return of the piston.
- ⑩ The filling speed is infinitely variable.

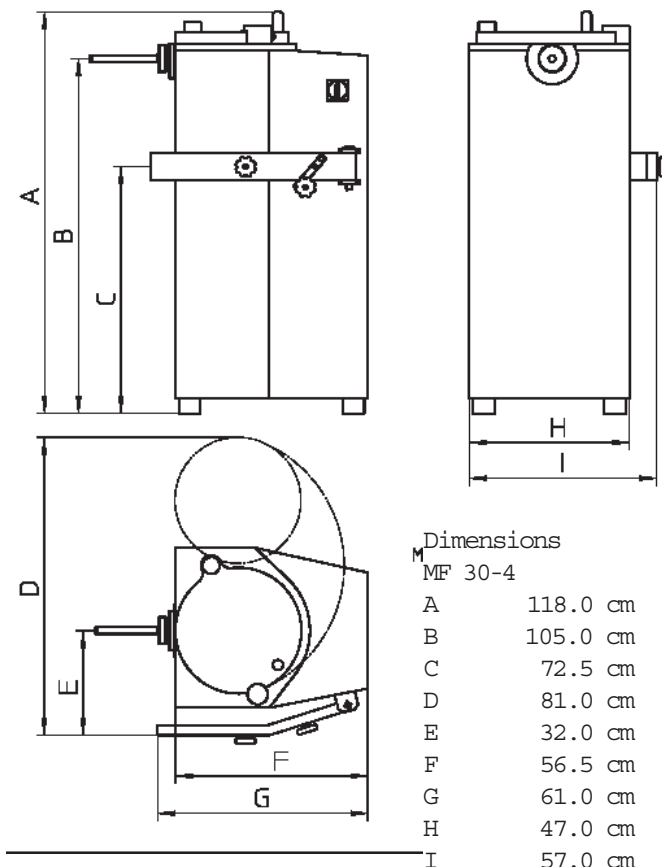

Subject to change

## Technical data MF 30-4

Capacity of the filling cylinder: 30 liters  
Automatic pressure release.  
Regulation infinitely variable

Current: three-phase  
Voltage: 230/400 V, 50 Hz  
Connected load: 1,1 KW,  
1400 turns/min.

Filling cylinder, piston: solid stainless steel

Housing: stainless steel

Cover: solid, stainless

### Accessories:

Filling tubes 12, 16, 25, 30 and 45 mm  
1 tube for lever sausage  
Closing nut  
Piston extractor

Special voltage on request

# K2-30 C60H



# C60H - control, the favourable alternative with all functions

A most modern control technology with CAN-Bus-system leaves nothing to be desired. The C60H control offers the same functions like the LCD3-control in compact finish.

- Weight input can be chosen between 5-10.000 g (from 5-999 g in 0,1 gr. steps)
- Number of links from 0 - 9,9 turns
- Normal and continuous operation
- Digital quantity counter
- Portioning pause  
Pauses between the portions are free selectable
- The quantity counter indicates how many pieces have been portioned, linked or filled. The counter can be reset to zero whenever you want.
- The automatic stop control stops automatically after the desired quantity has been produced. For skinned casings the length and the number of pieces per stick are always the same. After spooling a new casing Kompakta 2-30 has simply to be started. All the rest is done automatically.
- 99 filling programs can easily be stored in the memory of the machine. The advantage: No loss of time for storing the data. Your sausages are equally portioned and linked.
- 1st portion makeweight infinitely variable
- Ergonomic operation  
The operating zone has been arranged with a big operating comfort.

All information is clearly shown on the display.

-Additional appliances

Optionally a clipper socket is available for K2-30. Additionally appliances like clippers, ballformers or patty forming attachments can be controlled.



## Survey of functions of LCD 3 and C60H

K O M P A K T A 2 offers an inimitable variety of functions.

- ⑩ Weight input can be chosen between 5 and 100.000 g
- ⑩ Number of links from 0 - 9,9 turns
- ⑩ Clipping time (socket optionally available)
- ⑩ Preselection of pause for portioning and linking
- ⑩ Normal and continuous operation  
Normal operation as long as the operating bar is pressed and continuous operation by only pressing the operating bar for starting and stopping.
- ⑩ 99 filling programs
- ⑩ Table of contents
- ⑩ Service- and maintenance programs
- ⑩ Diagnosis programs
- ⑩ Counter of pieces
- ⑩ Preselection of pieces
- ⑩ 1st portion makeweight
- ⑩ Speed control infinitely, also during the filling process
- ⑩ Electric pulse control for automatic clipping machines
- ⑩ Interruption of meat flow by means of a rotary slide valve (no relieve)

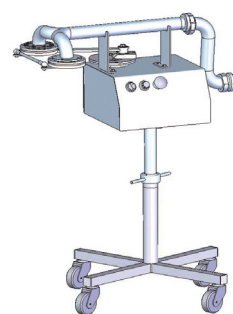
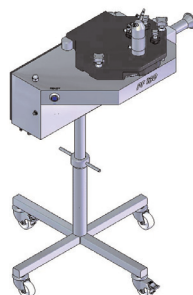



# K2-30 LCD3



# LCD3 - control

## Control technology of superlatives

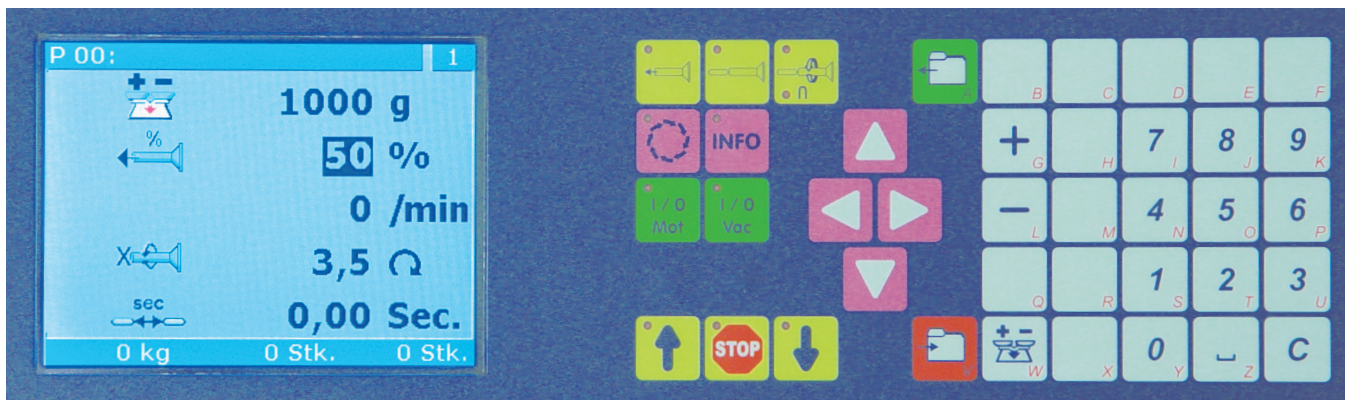

### Operation

KOMPAKTA 2 is controlled by a microprocessor with LCD colour display and background light. You always have everything under control. The brilliancy of this screen control unit is the diversity and the clearness of the shown information as well as the easy operation. The operator can go through the menus and choose the desired function using a cursor. The separation of the low current unit and the strong current unit allows a high reliability.

The programming The programming is extremely easy. It is not necessary to program in the usual sense, because KOMPAKTA 2 stores the actual settings of the machine by pressing the Save/Progr.-key under a chosen number. KOMPAKTA offers the possibility to store additional information, as e.g. the name of the product and the used filling tube. This data is shown on the display.

When pressing the Load/Progr.-key you can see all programs on the display in a table of contents. The operator can choose the desired program using a cursor and KOMPAKTA 2 is ready to fill. In this way KOMPAKTA 2 is reducing the standstills when changing the sorts

### Indication of contents

The actual content of the cylinder up to 0,1 liter is exactly shown on the display. You know if the casing is still filled or if you have to charge the stuffer.

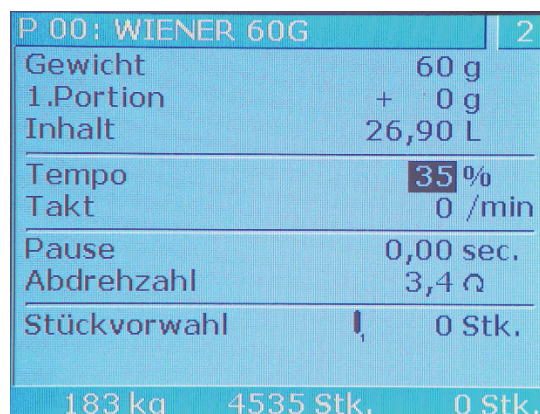
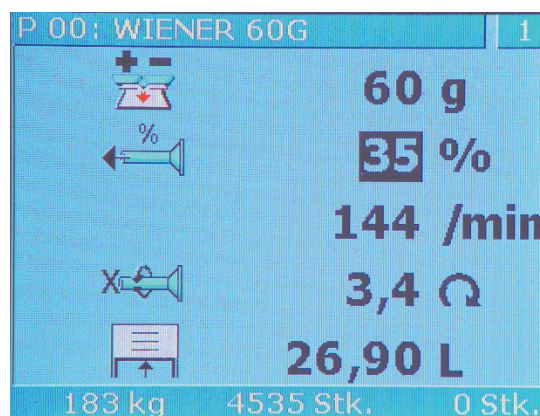

The keyboard is distinguished by a perceptible pressure point and the arrangement of the keys so that K 2 can be operated even without constant visual contact. The triple heat-sealed LCD-colour display is stabilized with a filter plate to guarantee a long service life. Of course the light intensity and the background light can be regulated.

# K O M P A K T A 2-30

By continuously realizing new ideas, our filling sufferer Kompakta 2 has finally reached the highest technical level and belongs to the top class of filling stuffers. The filling process has been improved and is now suitable for all types of sausages. The ideal technology of information and operation is the result of a good cooperation with butcher masters out of the practice for the practice.

Care for the sausage meat

In this new system we attached great importance to the care of the sausage meat. The wide and extremely short outlet guarantees a good quality also of coarse products. Because of this short outlet there are only little left-overs when changing the product.

Basically, K O M P A K T A 2 works like a straight filling machine. With the portioning piston and the linking device also portioning and linking is possible. The desired filling mode can be selected by simply pressing the according key on the keyboard.

The wide filling opening allows a quick charging of the machine and the handy swivelling cover without any locking device makes possible an easy opening and closing of the cover.

Thanks to the portioning piston of Kompakta 2 you have no relieve. There is no wearing out of the portioning piston, which can easily be taken out for cleaning. The use of special tools is not necessary. By moving back the piston, the product in the filling tube is sucked back.

A flexible change of the product is possible.

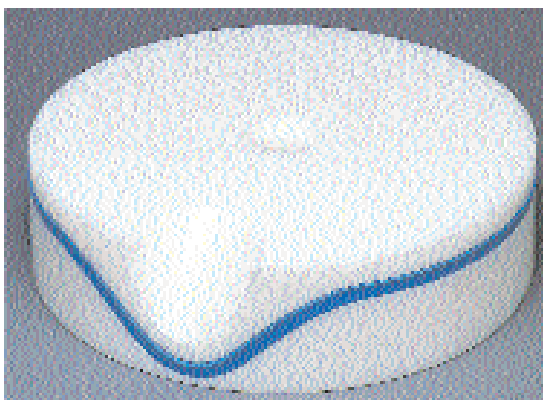

For developing the sausage piston we made special technical efforts

The groove of the gasket is now placed more upwards. No product can be found on the cylinder wall.

The groove has been reduced to a minimum, therefore you have only little left-overs when changing the sausage type.

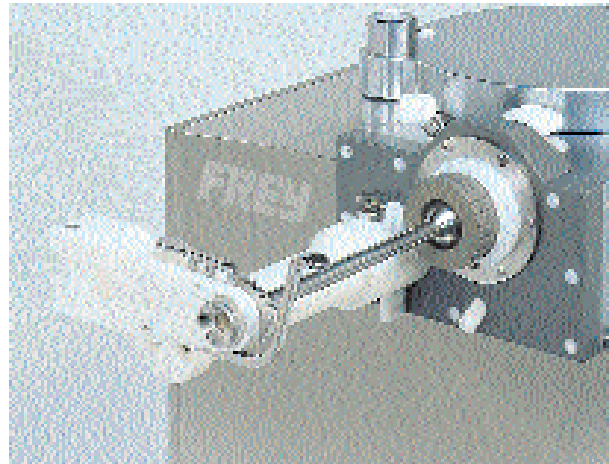
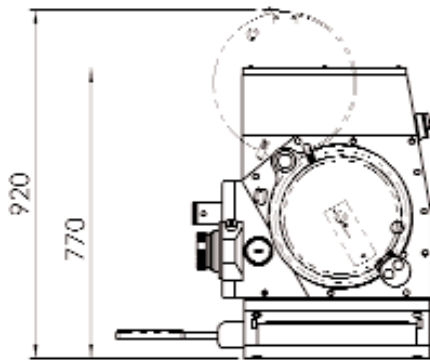
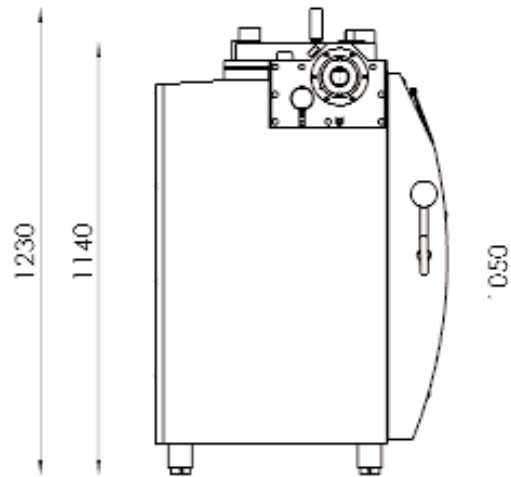
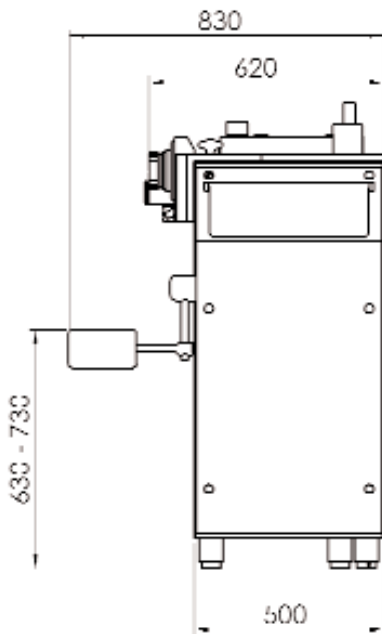

## Special accessories

A casing holder device DHGN for natural casings which is easy in handling is available as an accessory for KOMPAKTA 2.

The casing holder device makes the filling process faster and easier. You always get tight and solid sausages at maximum filling speed. The DHGN is maintenance-free because no drive is necessary.

In order to come up to your product diversity, you can receive special filling tubes or other additional equipment from us, individually made for you.

We would be pleased to inform you. Please call or write us.

## Technical data Kompakta 2

Capacity of the filling cylinder:	30 liters solid stainless steel
Sausage piston:	Hostaform C
Piston return:	9,0 seconds
Voltage:	400 V / 50Hz
Connected load:	
Linking motor:	1,1 KW
Pump motor:	2,2 KW
Finish:	grinded stainless steel
Accessories:	Piston extractor Filling tubes flange D58: 14,20 with groove for linking 24,30,42 for straight filling
Optionally:	Clipper socket casing holder device