

SE14-S-O



SE14-S-O



The SE14-S-O is a stationary mounted depositor. This chain line depositor has a built-in lifting table with integrated mold shaking.

Stationary floor-mounted depositor with dynamic hopper movement. The SE14 represents the ultimate depositor with its supreme build quality. All axes are servo driven and extremely strong for handling even the most difficult masses. A wide variety of piston diameters can be supplied to suit the smallest pralines or chips up to tablets with big inclusions. The hopper can be divided into multiple compartments for multi-color or one-shot depositing. The SE14 depositors have built-in lifting table with integrated mould shaking. The SE14 depositor is available for 700 and up to 1200 mm lines, working widths ranging from 580 to 1080 mm, however, the depositor can be made to suit any existing lines as well. Operation is very simple via the intuitive touch screen menu. Further the depositor can be connected to the internet, if any sort of support is needed.

UPS/EFU

- Cost-effective
- Handles big inclusions
- Total weight is reduced serverly by ligt weight material
- Easy cleaning and maintenance
- Easy and simple to operate
- Low energy consumption

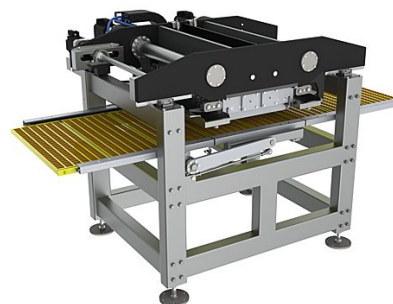

The Aasted Machinery Program

Find the technical specifications for the machine below.

	SE14-S-O 1200	SE14-S-O 700	SE14-S-O 1000
Capacity (kg/hour)			16320
Length (mm)			1850
Width (mm)			2100
Height (mm)			1650
Power usage (KwH)			29
Air usage (m3)			-
Water usage (m3)			0,013
Weight (kg)			1800

We have a broad portfolio of machinery and equipment

Beneath are listed products in the same category.

- test
- SE 13-O Belt
- SE14-Basic
- SE14-C-Basic
- SE14-C-DHD
- SE14-C-O
- SE14-C-O-DHD
- SE14-DHD
- SE14-O
- SE14-O-DHD
- SE14-O-OFL
- SE14-O-OFL-DHD