



SADDLE CUTTER 1



foodmate

Poultry Processing Systems

The Foodmate Saddle Cutter is the optimal machine to separate leg quarters. The guiding system is designed to always give an accurate center split.

The chicken which is hanging on the Foodmate Cut-Up Line is mounted parallel to the moving direction of the

machine, with the breast in the direction of the circular blade(s) of the Saddle Cutter. Because of the movement of the cut-up line and the help of the rails, the correct cut is realized. It can be mounted on new Foodmate lines or added to existing lines.

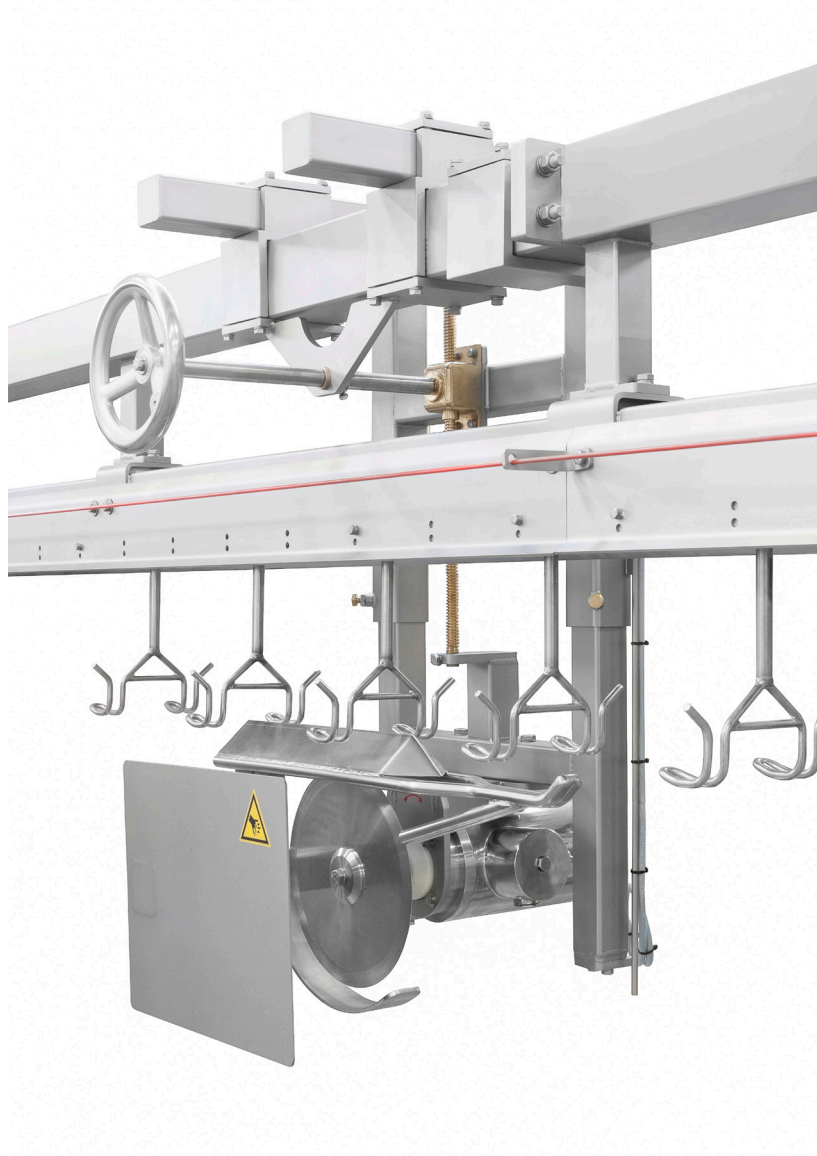

Our mission is to innovate, automate and bring cost-effective solutions to the industry.



SADDLE CUTTER 1

Key Benefits:

- Allows for a maximum of 6,000 birds per hour
- Allows for easy integration with the 8" to 12" lines due to its simple construction

Foodmate is an equipment manufacturing company based in the Netherlands. Founded in 2006, we focus primarily on poultry processing, and we recently launched Foodmate US, expanding our worldwide distribution into North America. Driven by research, paired with unmatched knowledge and decades of experience, it's our mission to innovate, automate and bring cost-effective solutions to the industry.

Our product line spans a wide assortment of processing equipment designed for live bird handling, killing and de-feathering, eviscerating, chilling, weighing, cut-up systems, deboning, and more. In addition to manufacturing, we provide an extensive variety of spare parts and service for other processing equipment and reconditioned machines.

Our team represents decades of industry knowledge and experience resulting in the engineering, development and implementation of new designs for our clients and their ever-changing needs.

Technical Specifications:

- Stainless steel frame and motor
- Motor (IP66) power is 0,75 kW
- Machine dimensions:
 Length: 679 mm
 Width: 700 mm
 Height: 1040 mm
 Weight: approx. 88 kg

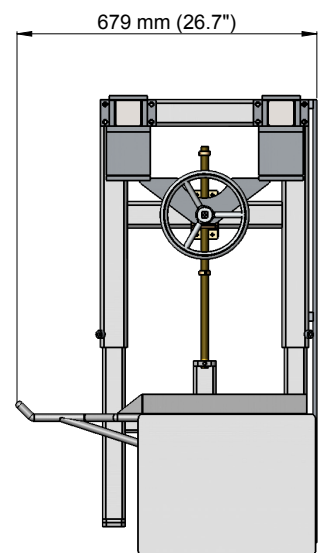
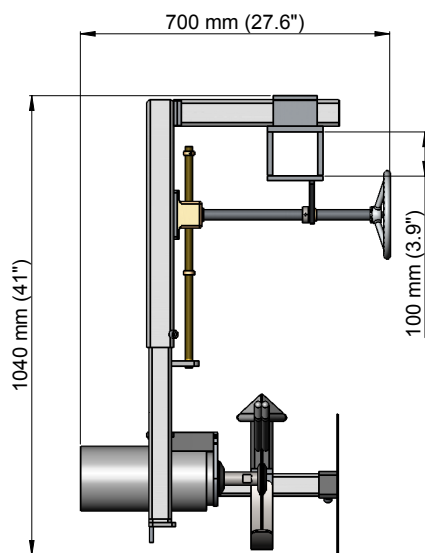

FOODMATE B.V.
 Röntgenstraat 18 • 3261 LK Oud-Beijerland
 P.O. Box 1405 • 3260 AK Oud-Beijerland
 The Netherlands
 Phone: +31-186 630240 • Fax: +31-186 630249
 info@foodmate.nl
 www.foodmate.nl

FOODMATE US, Inc.
 300 Wilbanks Drive, Ball Ground, GA 30107
 P.O. Box 4116, Canton, GA 30114
 U.S.A.
 Phone: +1-678-819-5270 (U.S.) • Fax: +1-678-819-5273
 info@foodmateusa.com
 www.foodmateus.com

