

SF Single L/R

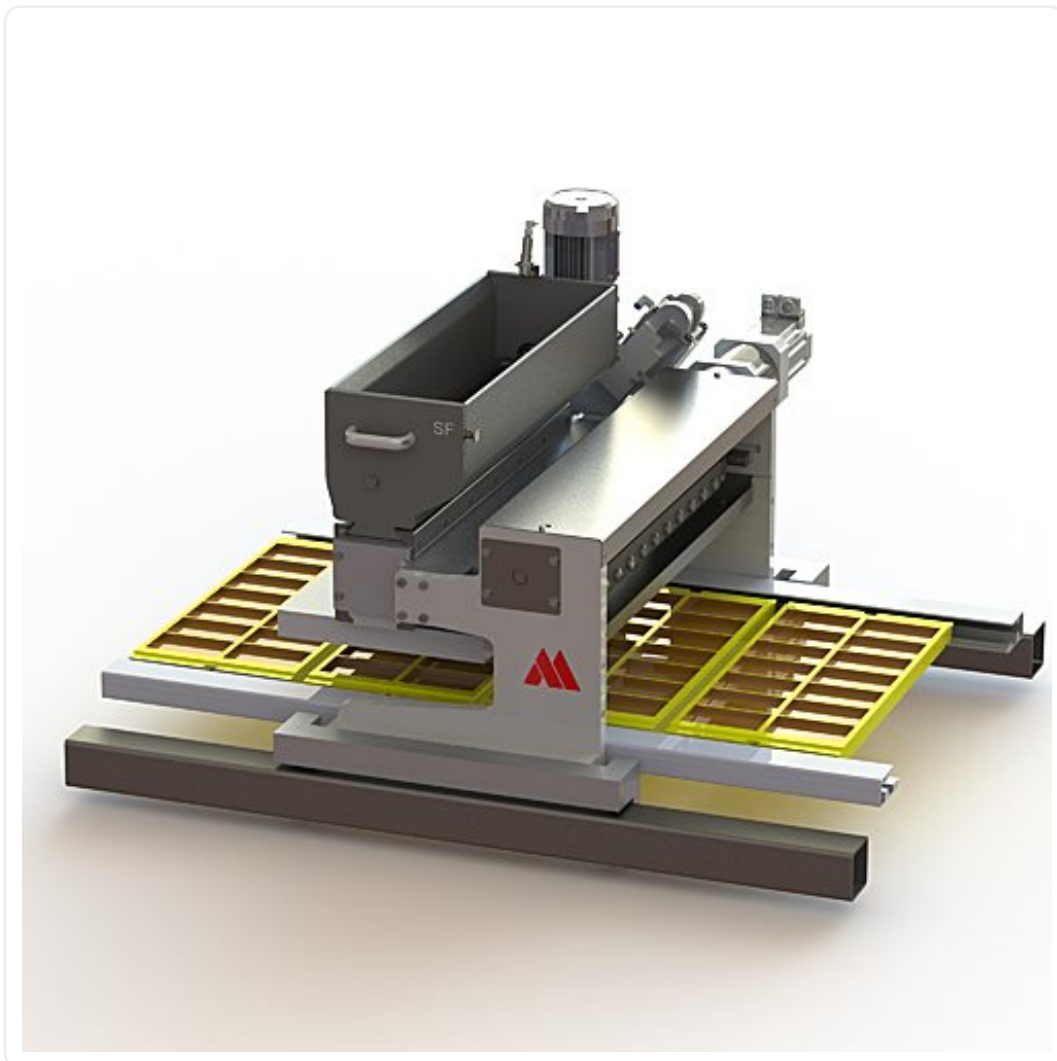

SF Single L/R



Stationary mounted depositor. Left or right mounted, can be built with left/right mounted to double.

Stationary, right or left mounted depositor. The SF line represents the flexible depositor with high build quality. The piston axis is servo driven for handling most masses. The rotary axes are servo or pneumatically driven. The SF is able to easily handle big inclusions. Depositing parts can be delivered in a wide variety to suit the demand, for example, multi-colour, one-shot, inclusions, chips and many more. The SF depositor is available for 500 and up to 1200 lines, working widths ranging from 380 to 1080 mm, however, the depositor can be made to suit any existing lines as well. Operation is very simple via the intuitive touch screen menu. Further the depositor is able to connect to the internet, if any sort of support is needed.

UPS/EFU

- Re-configuration of moulding for different products is easy and fast achievable
- Ensures high precision depositing
-
-
- Easy and simple to operate
- High flexibility

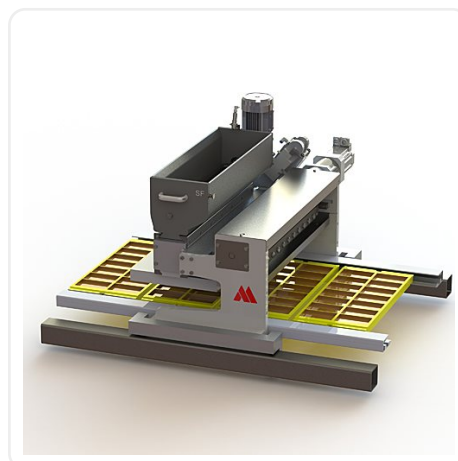

The Aasted Machinery Program

Find the technical specifications for the machine below.

	SF Single L/R 500	SF Single LR 700	SF Single L/R 1000	SF Single L/R 1200
Capacity (kg/hour)	2300	3900	5900	7500
Length (mm)	1200	1400	1700	1900
Width (mm)	571	571	571	571
Height (mm)	790	790	790	790
Power usage (KwH)	2	2	2	2
Air usage (m3)	12	12	18	18
Water usage (m3)	0,007	0,008	0,01	0,013
Weight (kg)	240	275	330	365

We have a broad portfolio of machinery and equipment

Beneath are listed products in the same category.

- SF Double L+R O
- SF Double L+R
- SF Double L+R V
- SF Double L+R V O
- SF Single L R O
- SF Single L R V
- SF Single L/R V O
- SF Triple L+R+T
- SF Triple L+R+T O
- SF Triple L+R+T V
- SF Triple L+R+T V O