

ZIEGRA Bruch-Eis Maschine
Typenblatt

ZBE 2.500 20°C

ZIEGRA Chip Ice Machine
Specification

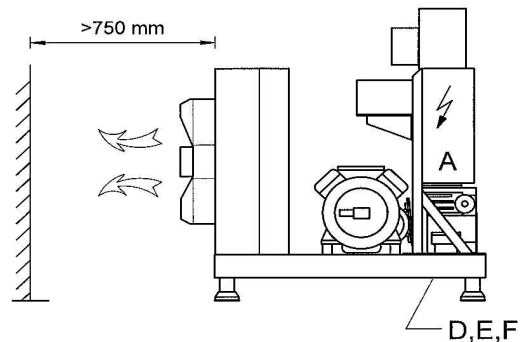
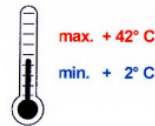
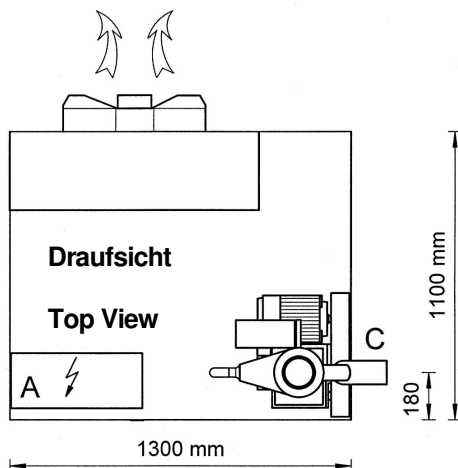
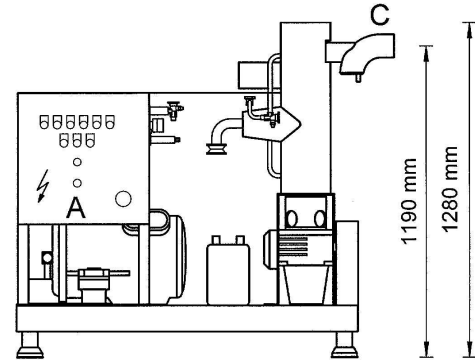

A:	Schaltkasten		control panel
C:	Eis-Auswurf	90 mm ø	ice hose
D:	Elt.-Anschluss	400V-3-50 Hz	electric connection
E:	Wasserzulauf	1-6 bar 1/2"	water connection
F:	Wasserüberlauf	14 mm ø	overflow

Bauseits vorsehen:

Schmutzfänger
 Absperrhahn
 Absicherung 50 A träge - slow
 Kabelquerschnitt 6 mm² Cu

Gewicht 500 kg

install on site:

filter
 stop valve
 fuses
 cable cross section

weight