

BAS+AHL

Industrial
filling
systems for
sausages



BAS system



Rational and flexible production of sausages

The BAS-system optimizes the production of sausages equal in length and weight.

- Artificial-/Cellulose casing
- Collagen casing
- Natural casing

With the BAS-system the constant working performance of your filling station can be increased.

BAS-systems are driven by a servo motor with positioning regulation. The motor is synchronized with the stuffer via the FREY CAN BUS system. The sausages can be produced with an equal length. Caliber differences of the casings can be compensated.

The operation is centrally controlled via the filler control TC733. All necessary parameters can be set and saved with the filler program. A flexible change of sorts is possible.

BAS02 /SA

With BAS02/SA in connection with the casing holder device DHGA the highest rationalization level can be achieved, due to the fully automatic opening and closing of the complete unit.

The integrated servo linker guarantees an utmost accuracy, working speed and process reliability. Thanks to the straight and short ways of the product even critical products, like raw sausages can fast be produced without any problem.

BAS02/SA can be combined with the grinding head system WK130. The product quality can considerably be improved.

All BAS-systems are mobile. With the ball joint connector they can fast be connected to the filling stuffer. Very short preparing times are necessary. The machines are completely made of stainless steel and meet the highest hygienic standard.



TC733

control of the sausage production

All parameters can be set via the filler control TC733. To facilitate the determination of the sausage length and filling speed the control is equipped with various calculation programs.

Three different working modes are possible.

Calibers of 13 - 42 mm and sausage lengths of 30 - 500 mm can be produced.

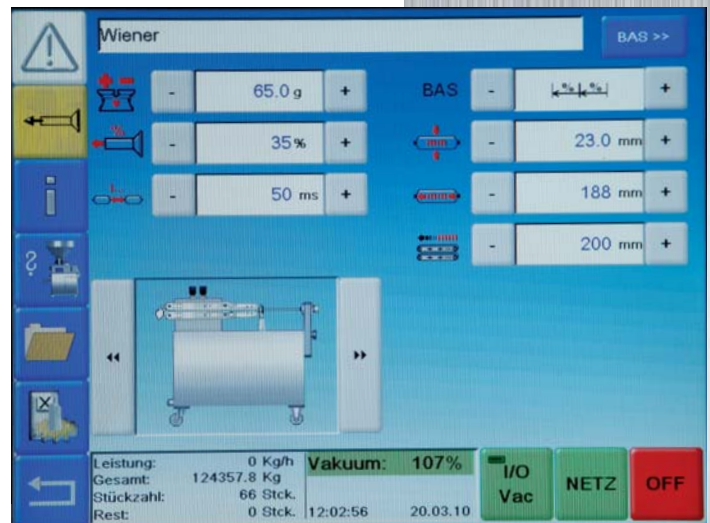

AHL02

The hanging line system AHL can be connected with the BAS-system. At the taking-over point the sausages are taken over by the hanging line and transported onto flexible hooks. The distance between the hooks can be modified by using the plug-in system.

The following functions of the AHL system are possible:

- Grouping mode
- Continous mode

The distance between the hooks can be selected.

- Pieces on the first hook
- Pieces on all hooks
- Hook groups
- Empty hooks
- Empty portions
- Approach and take-over ways
- Approach and take-over speed
- Automatic piece calculation

By using acceleration ramps the servo drive of the hanging line allows to adjust the driving speed also to sensible products.

AHL systems are movable and can flexibly be used.

The electronic control elements are integrated in the BAS systems and are well-protected. The machine is connected via a waterproof plug.

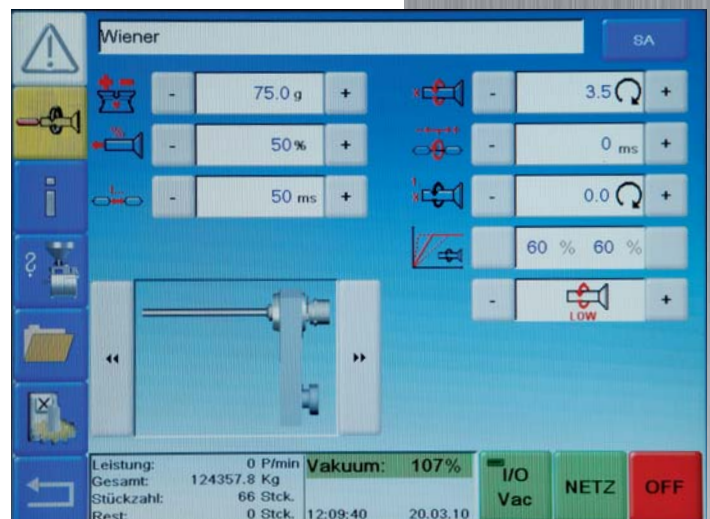
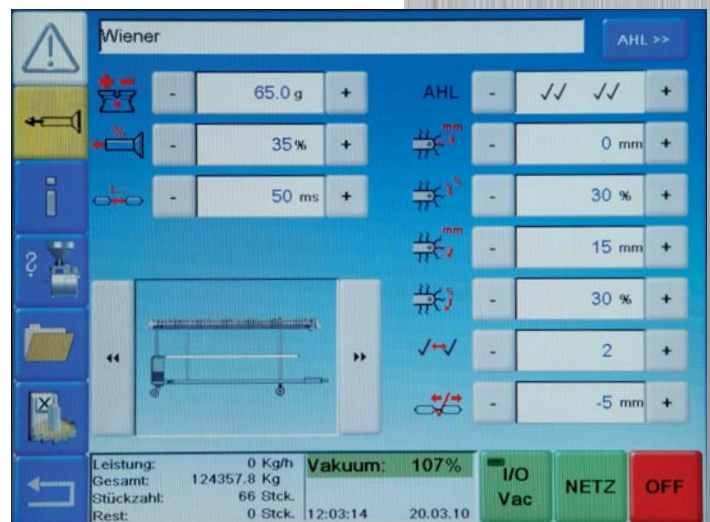

Application range of BAS 02



BAS 02 in connection with DHGA 330 or 380mm

- Equal in length
- Equal in weight

for

- Natural casing
- Collagen casing
- Artificial casing

optionally

DA2002/DAS2004

Ideal for the production with natural casings.
Flexible and easy operation with integrated water injection.

Automatic opening and closing of BAS02.

Manual function of the DHGA.

F-Line with linker is required.



BAS 02 in connection with AHLo2

- Equal in length
- Equal in weight
- Hung-up sausages

for

- Natural casing
- Collagen- and artificial casing

optionally

DA2002/DAS2004

For all casing types.

Flexible and easy operation with integrated water injection.

Automatic opening and closing of BAS02.

Manual function of the DHGA.

Machine with linker is required.



BAS 02 /SA (semi-automatic)

- Equal in length
- Equal in weight
- Integrated high speed servo linker
- Pneumatically driven DHGA

for

- Natural casing
- Collagen- and artificial casing

optionally

DA2002/DAS2004

Combinable with grinding head system WK130

For all casing types.

Recommended to achieve highest linking performance.

Shortest preparation time for casings.

Flexible and easy operation with integrated water injection.

Also for vacuum stuffers of the P series.

For WK130 machines an additional servo drive is required.



BAS 02 /SA in connection with AHLo2

see BAS 02 /SA

Additional hanging function

On demand an elevated hook position of 120 mm is possible

Application range of BAS 02 / BAS 02 SA



BAS 02 in connection with a sausage cutting machine

- Equal in length
 - Equal in weight
 - Separated sausages
- for optionally

- Natural casing DA2002/DAS2004
- Collagen casing

Ideal for the production with natural and collagen casings with cutting device (e.g. breakfast sausages, Merguez)

Flexible and easy operation with integrated water injection.

- Mechanical connection
- Mechanical transport to the cutting machine
- Electronic control
- Digital synchronisation

Separation of the sausage chains adjustable from 1-10 pieces.

Place saving



AHLo2 in connection with the ClipEx closing machine and guiding rail

The **ClipEx** closing machine is closing sheep and porc casings in the sausage production. The end of the natural casing is led into the threader and welded by the welding jaws. The end of the casing is cut off. The closing point is ready for sale with best optics.

Guiding rail

For the universal use with hanging lines of any producer. Parallel to the movement of the sausages the closing machine can be moved over the whole production distance.

Optional foot drive.



Technical data

Voltage / tension 400V/50Hz
 Special voltage on request



BAS 02

Caliber 13-42 mm
 Sausage length: 30-500 mm
 Drive mode: Global Drive
 Drive power: 3,2 Kw
 Portioning speed max. 700 port/min.
 (depending on the F-Line model)
 Weight: 300 kg
 Accessories: 1 set of belts, 1 slide
 Filling stuffer with linker and DHGA is necessary.

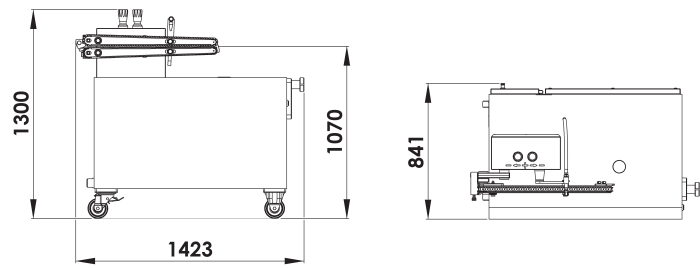

BAS 02 /SA

integrated DHGA
 Caliber 13-42 mm
 Sausage length: 30-500 mm
 Drive mode: Global Drive
 Drive power: 3,2 Kw
 Drive of portioning belt: 3,2 Kw
 Servo linker 3,2 Kw

 Portioning speed max. 800 port/min.
 Weight: 350 kg
 Accessories: 1 set of belts, 1 slide,
 2 linking tube 380
 1 integrated DHGA

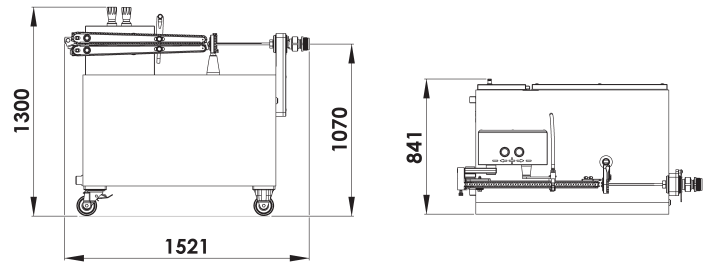

BAS 02 /SA + AHL 02

integrated DHG-N
 Caliber 13-42 mm
 Sausage length: 30-500 mm
 Drive mode: Global Drive
 Drive power: 3,2 Kw
 Drive of portioning belt: 3,2 Kw
 Servo linker 3,2 Kw
 AHL 02 0,6 Kw

 Portioning speed max. 800 port/min.
 Weight: 350 kg
 BAS02 /SA 135 kg
 AHL 02 135 kg
 Accessories: 1 set of belts
 2 linking tubes 380
 1 integrated DHGA
 120 hooks, base sheet
 adjustable in height,
 deflector and slide

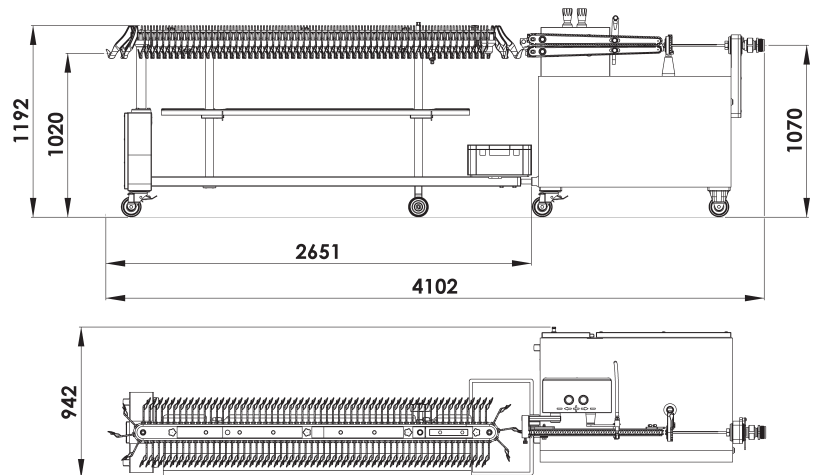

BAS 02 + AHL 02 see BAS02/SA+AHL02
 0,6 Kw / 135 kg
 120 hooks, base sheet
 adjustable in height,
 deflector and slide

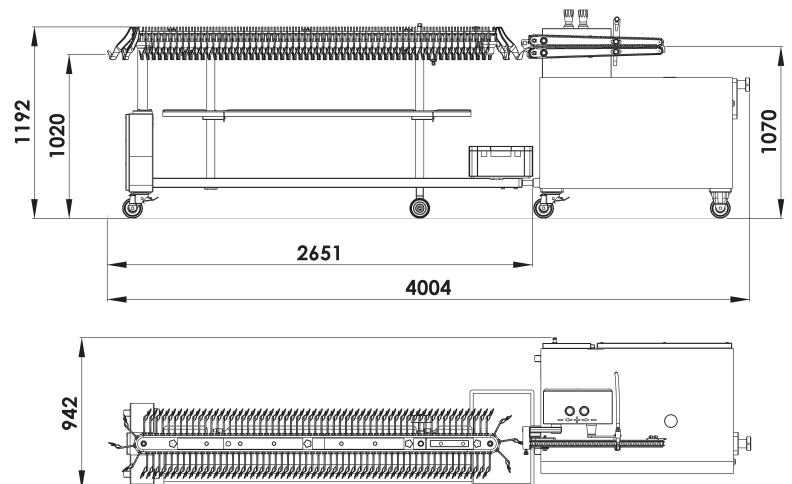

Heinrich Frey Maschinenbau GmbH

Fischerstr. 20
 D-89542 Herbrechtingen
 Germany
 Phone +49 7324 172 0
 Fax +49 7324 172 44
 Internet: www.frey-maschinenbau.de
 Email: info@frey-maschinenbau.de

Technical modifications are subject to changes