

Alice™ Z Dynamic Double

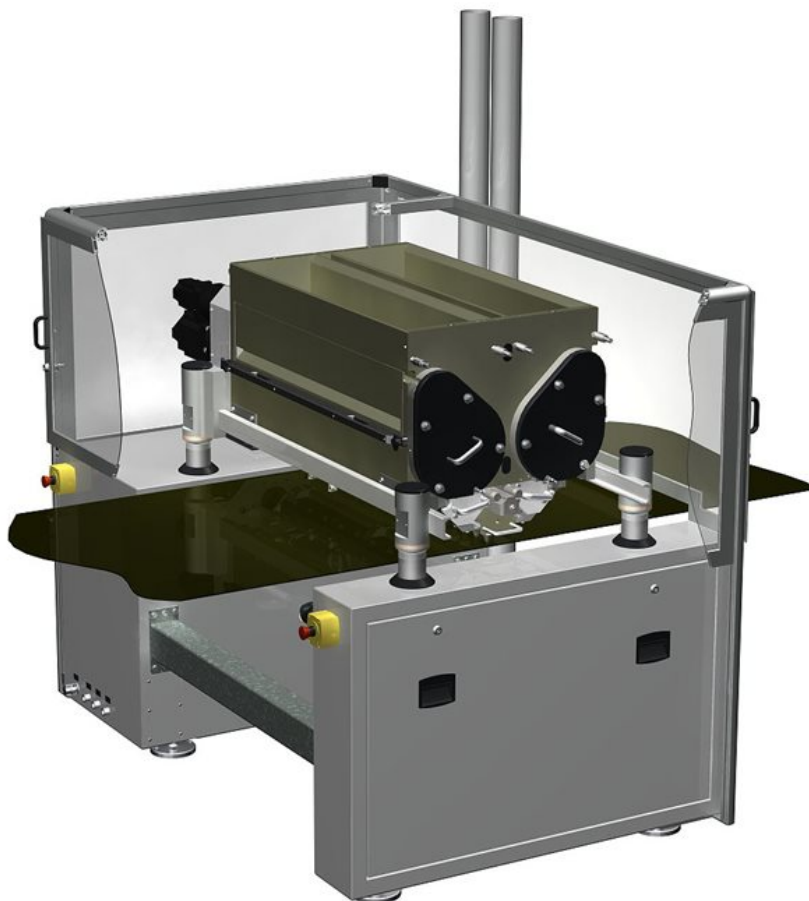

Alice™ Z Dynamic Double

Choose the Alice™ depositor in double head configuration you can combine two different masses into one deposited, extruded or wire-cut product.

Configuration is used for co-extrusion, sandwich extrusion, double-row extrusion, sequence depositing and more.

Choose the Alice™ Z dynamic depositor in double head configuration and you can combine two different masses into one extruded or wire-cut product. This configuration is used for co-extrusion, multi color depositing and drop fill depositing – create sophisticated and innovative products by combining different masses and fillings. All movements are servo driven and fully programmable. All programming is done from a color touch screen panel and can be adjusted in real time. Choose this configuration if you wish to produce complex extruded shapes onto a continuously moving conveyor. The machine is easy to clean. The Alice™ hopper also makes it adaptable to quick product changes thanks to its off-line capability. Upgrade to triple head configuration is possible.

UPS/EFU

- Preserves dough structure and texture
- Provides extremely fast change-overs
- Unique "hose-down" cleaning
- Large selection of innovative die tools
- Gently handles dough with inclusions
- Handles aerated masses

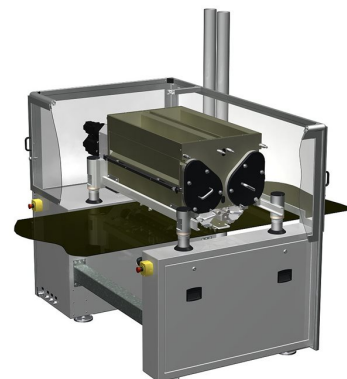

The Aasted Machinery Program

Find the technical specifications for the machine below.

	Alice™ Z Dynamic Double 1000	Alice™ Z Dynamic Double 800	Alice™ Z Dynamic Double 1200	Alice™ Z Dynamic Double 600
Length (mm)	2188	1988	2388	1788
Width (mm)	1543	1543	1543	1543
Height (mm)	1878	1878	1878	1878
Power usage (KwH)	35	35	35	35
Air usage (m3)	75L/min. 6 bar / 4.5	75L/min. 6 bar/ 4.5	75L/min. 6 bar / 4.5	75 L/min 6 bar / 4.5
Water usage (m3)	26L/h. /	20L/h. /	32L/h. /	14L/h. /

We have a broad portfolio of machinery and equipment

Beneath are listed products in the same category.

- Alice™ Z Dynamic Single
- Alice™ Z Dynamic Triple