



AUTOMATIC EVISCERATOR



foodmate

Poultry Processing Systems

The Foodmate Automatic Eviscerator is utilized for various types of poultry, to draw the intestine pack with giblets after vent cutting and opening of the birds. The intestine package with giblets attached are positioned on the back of the bird that is still attached for veterinary inspection of both. The heart, liver and gizzards are presented for easy harvesting. With product within the set product weight range, the machine has hardly any fall back or loss of packs and the performance rate, with regards to recovery of edibles, is 90% or higher.

Fitted for 16/24 eviscerating units that, due to the breast holder, position the birds in the correct way prior to starting to draw. This machine allows for adjustable infeed timing, height adjustment for different weight ranges, total machine timing, and breast holder tension. The Eviscerator needs to be hooked up to the main water supply to clean each unit after each cycle. It is stainless steel and food approved nylon constructed and is driven by the overhead conveyor system.

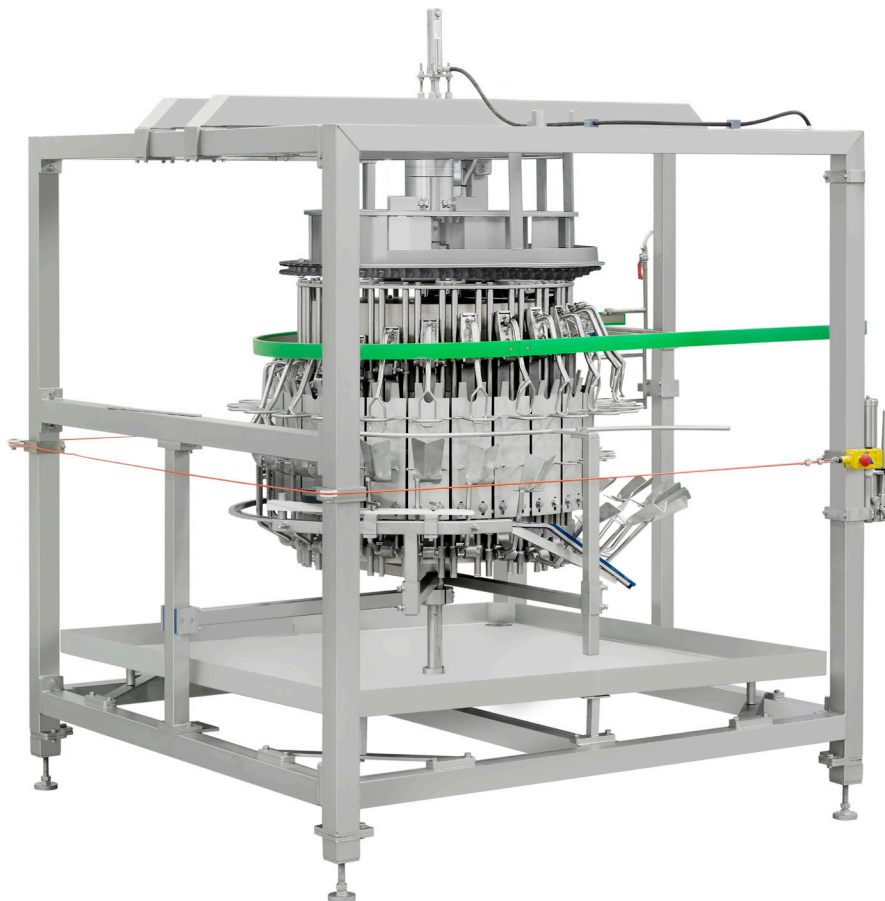

Our mission is to innovate, automate and bring cost-effective solutions to the industry.



AUTOMATIC EVISCERATOR

Key Benefit:

- Allows for a maximum of 9,000 birds per hour

Foodmate is an equipment manufacturing company based in the Netherlands. Founded in 2006, we focus primarily on poultry processing, and we recently launched Foodmate US, expanding our worldwide distribution into North America. Driven by research, paired with unmatched knowledge and decades of experience, it's our mission to innovate, automate and bring cost-effective solutions to the industry.

Our product line spans a wide assortment of processing equipment designed for live bird handling, killing and de-feathering, eviscerating, chilling, weighing, cut-up systems, deboning, and more. In addition to manufacturing, we provide an extensive variety of spare parts and service for other processing equipment and reconditioned machines.

Our team represents decades of industry knowledge and experience resulting in the engineering, development and implementation of new designs for our clients and their ever-changing needs.

Technical Specifications:

- Stainless steel frame
- Units: 16 or 24
- Pitch: 6" or 8"
- Rotation: CW/CCW
- Conveyor type:
 - Pipe
 - T-track
- Machine dimensions
 - Length: 2295 mm (units 16)
2696 mm (units 24)
 - Width: 1600 mm (units 16)
2000 mm (units 24)
 - Height: 2649 mm
 - Weight: approx. 925 kg (units 16)
approx. 1425 kg (units 24)

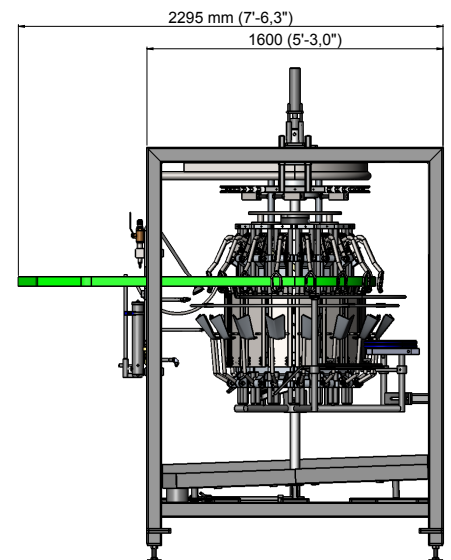
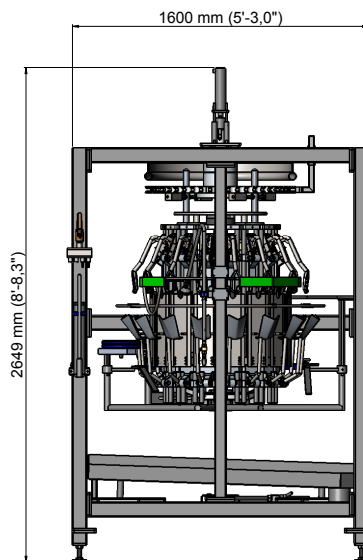

FOODMATE B.V.
Röntgenstraat 18 • 3261 LK Oud-Beijerland
P.O. Box 1405 • 3260 AK Oud-Beijerland
The Netherlands
Phone: +31-186 630240 • Fax: +31-186 630249
info@foodmate.nl
www.foodmate.nl

FOODMATE US
300 Wilbanks Drive, Ball Ground, GA 30107
P.O. Box 4116, Canton, GA 30114
U.S.A.
Phone: +1-678-819-5270 (U.S.) • Fax: +1-678-819-5273
info@foodmateusa.com
www.foodmateus.com

