

Band Saws

BS 502 Table Top Model

BS 504, BS 505, BS 507 Floor mounted with fixed table

BS 506, BS508 Floor mounted with sliding table

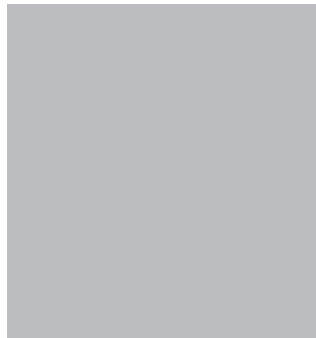
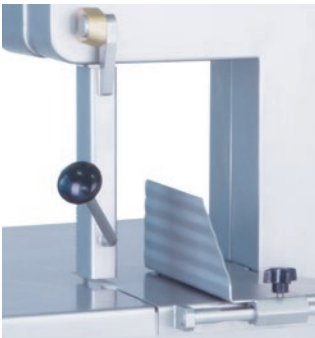

Band Saws

High performance band saws for the professional cutting of all kinds of food material, no matter if it is fresh or frozen, with or without bones. For each size of operation the ideal machine for customers, who are demanding excellence from their equipment.

For butcheries, meat processing plants, meat packers, retail stores and catering companies, six models in four different sizes are available. Therewith all cutting processes can be done safe, precise and quick with a very proper cutting surface.

● BS 506



● BS 505



The machines are fully made from high degree stainless steel. The machine body is welded together completely gap free for an easy, quick and hygienic proper cleaning. All **CE** requirements regarding safety and hygiene are fulfilled.

IFOOMA®

Quality + Innovation



● BS 502

The **IFOOMA** band saws feature with their versatility, solidity, safety, reliability persistence and they are very easy to clean.

The solid finish of the machine body in first class workmanship together with the precise working blade tensioning device guarantee an excellent vibration level with very low noise emission during operation.

The blade and wheel scrapers work very effective. They can be removed quickly and easily without tools. The removable safety pushing bar* and the portioning device, equipped with fine tuning application as a standard, can be stored safely on the side of the machine body on the foreseen brackets.

The model **BS 502** with fixed table is optional also available with a movable stand

The machine table of all models can be flapped up to replace the saw blade and for the machine cleaning.

The models **BS 506 and 508** are additionally equipped with a sliding table. The rollers are equipped with solid ball bearings for a precise and smooth run of the table. Heavy and big materials for example T-bone steaks or frozen meat blocks can be moved effort-saving for a proper cut. For cleaning, this table also can be flapped up.

The high quality sealing of the saw blade wheels for all models provides a pressure water protection for the ball bearings. The achievement is a long life cycle.

*not for BS 502

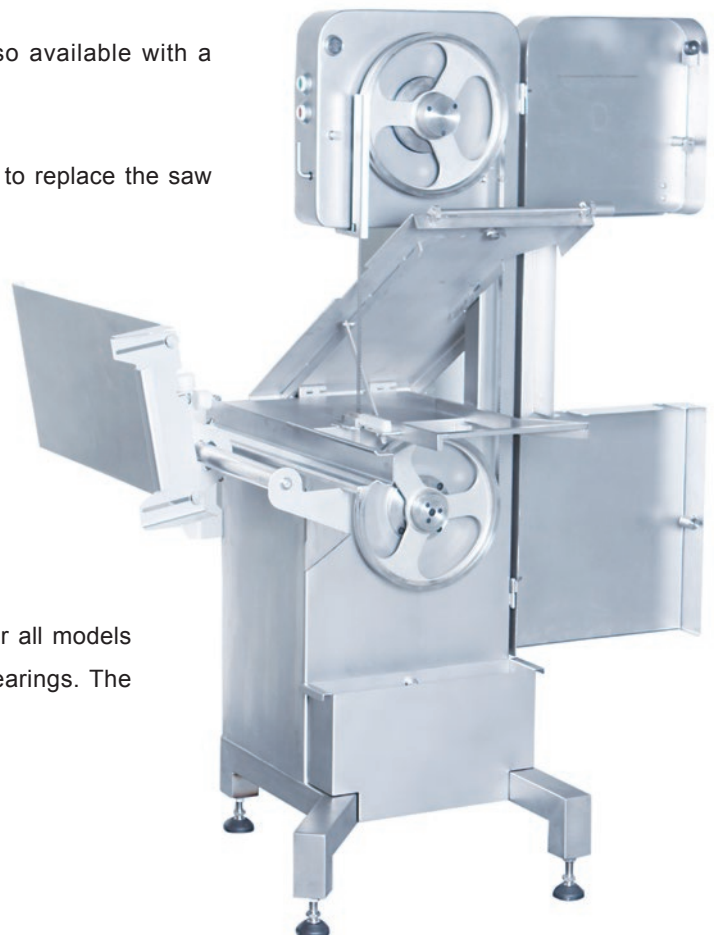

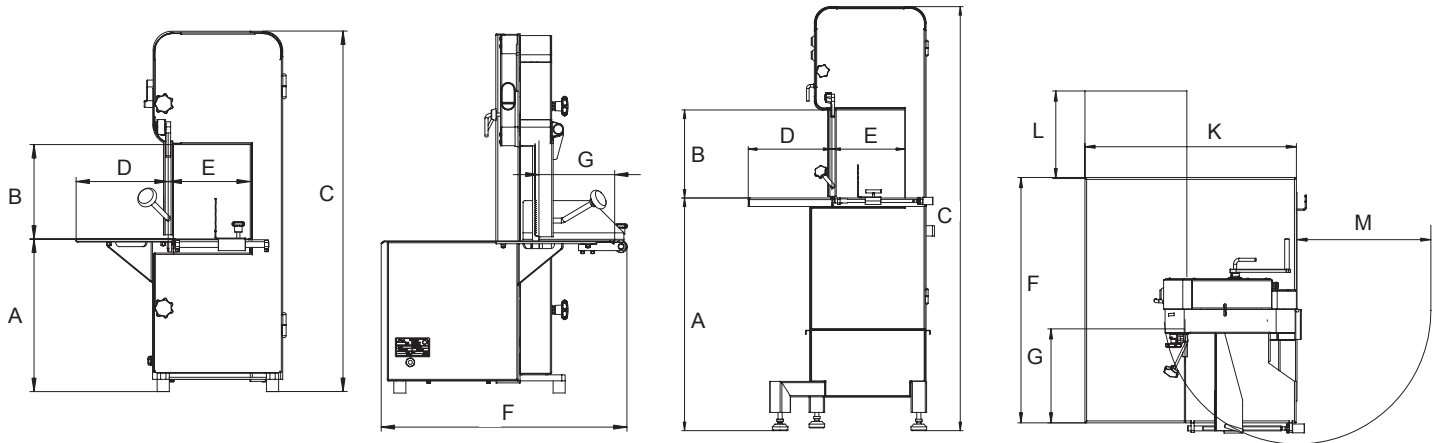

Type	BS 502	BS 504	BS 505	BS 506	BS 507	BS 508
A	370 mm	870 mm	900 mm	900 mm	900 mm	900 mm
B	235 mm	290 mm	340 mm	340 mm	410 mm	410 mm
C	940 mm	1500 mm	1640 mm	1640 mm	1800 mm	1800 mm
D	220 mm	230 mm	325 mm	365 mm	400 mm	435 mm
E	190 mm	230 mm	280 mm	280 mm	400 mm	400 mm
F	620 mm	710 mm	820 mm	850 mm	880 mm	940 mm
G	190 mm	240 mm	320 mm	320 mm	375 mm	375 mm
K	495 mm	550 mm	710 mm	710 mm	910 mm	910 mm
L				375 mm		400 mm
M	325 mm	370 mm	425 mm	425 mm	565 mm	565 mm
Voltage	400 V, 50Hz, three phase	400 V, 50Hz, three phase	400 V, 50Hz, three phase	400 V, 50Hz, three phase	400 V, 50Hz, three phase	400 V, 50Hz, three phase
Power	1,1 kw	1,1 kw	1,5 kw	1,5 kw	2,2 kw	2,2 kw
Fusing	16 A inert	16 A inert	16 A inert	16 A inert	16 A inert	16 A inert
Revolution rpm	1450	1450	1450	1450	950	950
Cutting Speed	17 m/sec	20 m/sec	22 m/sec	22 m/sec	20 m/sec	20 m/sec
Saw Blade Dimension	1750x16 x0,45 mm	2170x16 x0,45 mm	2430x16 x0,45 mm	2430x16 x0,45 mm	3150x16 x0,45 mm	3150x16 x0,45 mm
Weight approx.	75 kg	110 kg	120 kg	130 kg	170 kg	180 kg

