



HORIZONTAL SLICING MACHINE HSM -2



foodmate

Poultry Processing Systems

- Designed to feed newest dual lane portioners
- Two lanes with independent height adjustment and slice thickness
- Variable belt speed, max. 80 feet per min.
- Portion Removal to either side of the slicer
- Superior cut with short oscillating blade
- Long blade life
- No heat development, no cooling water needed
- Floating hold down belts
- Allan Bradley inverters for variable belt speed and slicing speed
- Designed for operator friendly and quick adjustments, machine controls on product loading side
- Properly guarded for safe operation, complies with latest safety and hygiene requirements
- Cleans easily with only slicing kits to be removed
- Extremely heavy-duty, designed for minimum downtime and maintenance
- Powerful gear motors
 - 1 x slicing unit
 - 1 x bottom conveyor belt
 - 1 x top compression belt
- Conveyor belts 330mm/13" wide with FDA quick connectors
- Made in stainless steel and other FDA approved non corrosive materials
- Water spray system for top and bottom belts optional



Our mission is to innovate, automate and bring cost-effective solutions to the industry.



HORIZONTAL SLICING MACHINE HSM -2

Key Benefits:

- Butterfly slicing kit for single chicken fillets
- For product height up to 50 mm / 2"
- For product width from 50 mm / 2" to 140 mm / 5 1/2"
- With slicing kits for up to 5 blades

Foodmate is an equipment manufacturing company based in the Netherlands. Founded in 2006, we focus primarily on poultry processing, and we recently launched Foodmate US, expanding our worldwide distribution into North America. Driven by research, paired with unmatched knowledge and decades of experience, it's our mission to innovate, automate and bring cost-effective solutions to the industry.

Our product line spans a wide assortment of processing equipment designed for live bird handling, killing and de-feathering, eviscerating, chilling, weighing, cut-up systems, deboning, and more. In addition to manufacturing, we provide an extensive variety of spare parts and service for other processing equipment and reconditioned machines.

Our team represents decades of industry knowledge and experience resulting in the engineering, development and implementation of new designs for our clients and their ever-changing needs.

Technical Specifications:

- Stainless steel frame and motor
- Motor (IP66) power supply:

- 3 x 2,7 kW

Machine dimensions:

- Length: 2924 mm
- Width: 1306 mm
- Height: 1320 mm
- Weight: approx. 550 kg

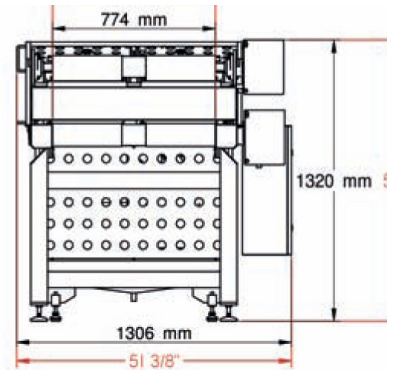
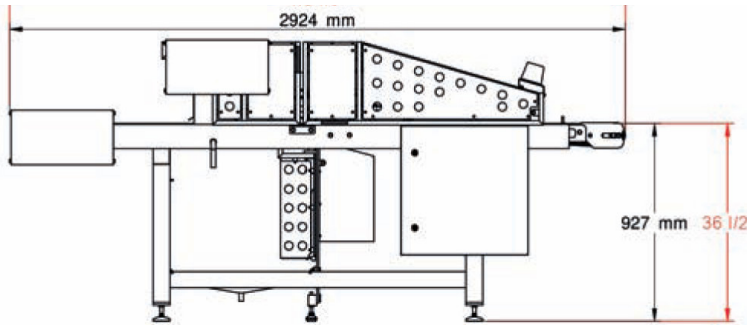

FOODMATE B.V.
 Röntgenstraat 18 • 3261 LK Oud-Beijerland
 P.O. Box 1405 • 3260 AK Oud-Beijerland
 The Netherlands
 Phone: +31-186 630240 • Fax: +31-186 630249
 info@foodmate.nl
 www.foodmate.nl

FOODMATE US, Inc.
 300 Wilbanks Drive, Ball Ground, GA 30107
 P.O. Box 4116, Canton, GA 30114
 U.S.A.
 Phone: +1-678-819-5270 (U.S.) • Fax: +1-678-819-5273
 info@foodmateusa.com
 www.foodmateus.com



foodmate