

SE14-C-DHD

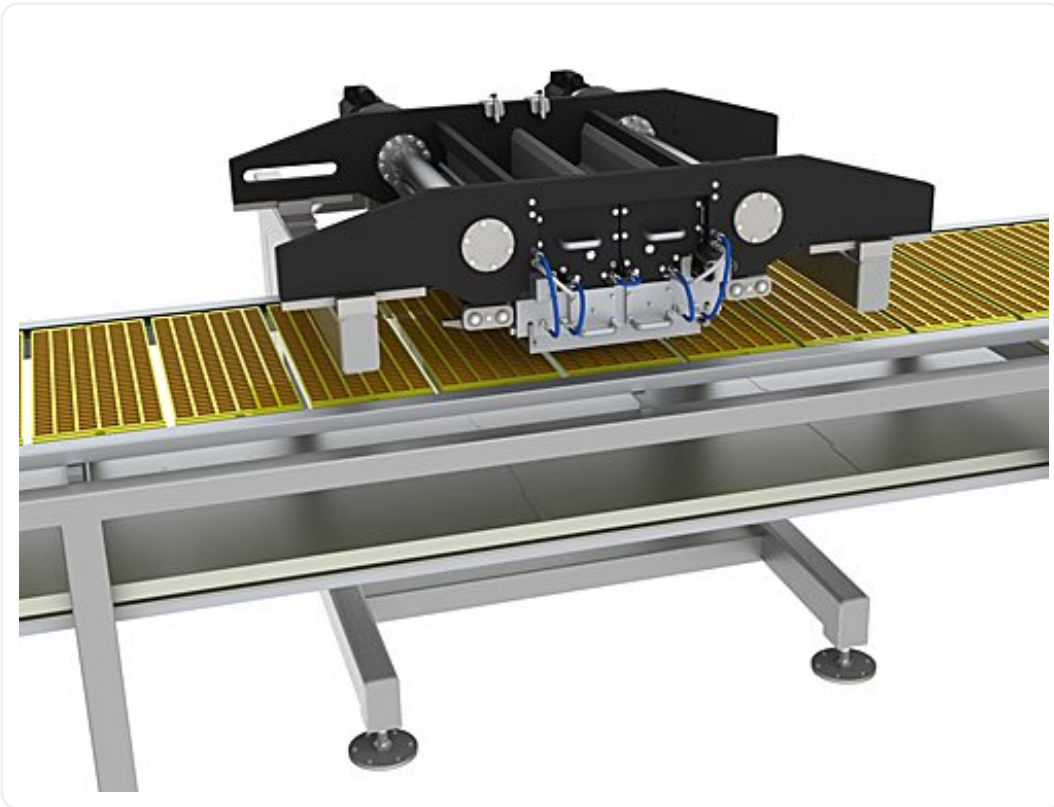

SE14-C-DHD

The SE14-C-DHD is a C-frame depositor for all lines. Equipped with a detachable hopper and depositing parts. Easily maneuverable for cleaning and re-positioning.

With its C-frame, the depositor is easy to move around for cleaning or placing in another position on the line. With its detachable hopper and depositing parts, it is easy to change hoppers and depositing parts for running of another product or cleaning.

The SE14 represents the ultimate depositor with its supreme build quality. All axes are servo driven and extremely strong for handling even the most difficult masses. A wide variety of piston diameters can be supplied to suit the smallest pralines or chips up to tablets with big inclusions. The hopper can be divided into multiple compartments for multi-color or one-shot depositing. The SE14 depositors have built-in lifting table with integrated mould shaking. The SE14 depositor is available for 500 and up to 700 mm lines, working widths ranging from 380 to 580 mm, however, the depositor can be made to suit any existing lines as well. Operation is very simple via the intuitive touch screen menu. Further the depositor can be connected to the internet, if any sort of support is needed.

UPS/EFU

- Well suited to deposit bars in either solid or one-shot
-
- Easy to clean and maintain
- Easy to move around for cleaning or to put in another position on the line
- High quality
- Low energy consumption

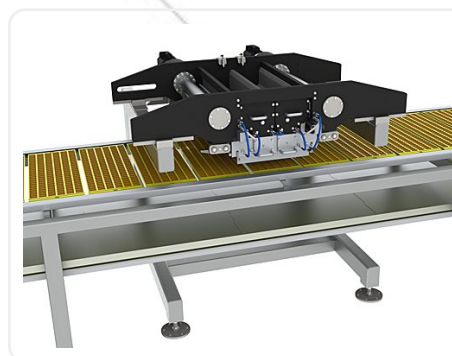

The Aasted Machinery Program

Find the technical specifications for the machine below.

	SE14 C DHD 1000	SE14 C DHD 700
Capacity (kg/hour)		11420
Length (mm)		-
Width (mm)		1850
Height (mm)		1650
Power usage (KwH)		25
Air usage (m3)		-
Water usage (m3)		0,009
Weight (kg)		-

We have a broad portfolio of machinery and equipment

Beneath are listed products in the same category.

- test
- SE 13-O Belt
- SE14-Basic
- SE14-C-Basic
- SE14-C-O
- SE14-C-O-DHD
- SE14-DHD
- SE14-O
- SE14-O-DHD
- SE14-O-OFL
- SE14-O-OFL-DHD
- SE14-S-Basic