

## Belt Cutter GS 20



Multi purpose lettuce and vegetable belt cutter designed and constructed for the food processing industry



# GS 20 Belt Cutter



## Versatility and capacity in one machine – Cutting machine for lettuce, herbs, vegetables and fruit up to 4 tons per hour

The GS 20 belt cutting machine is equipped with a conveyor belt 250 mm wide with a product down-holder to apply proper pressure for product control. This key feature holds and controls the product until point of cutting. Individually definable programs can be stored and selected by the simple use of control buttons and features digital in-motion cutting size adjustment from 1 to 50 mm using a knife with 3 blades. The GS 20 feeding belt has been designed to convey whole heads of lettuce or cabbage. The easy handling joins our series of all established KRONEN GS belt cutting machines. Concerning the product outfeed the knife cover has been optimized, in order to allow a gentle product handling. The downholder gear and the diversion rollers were further improved and spare parts reduced consistently as far as

possible, taken into account an additional improvement of the product quality. Indicator lights indicate the status of the safety sensors. A new locking system combined with a new belt cover creates additional safety in the area of the knife. As with all KRONEN machines, its excellent hygiene qualities are a major advantage: Inclined surfaces, stainless steel shaft seals and the elimination of screws in the cutting chamber door area, a seamless knife edge, etc. contribute to the improved performance of the GS 20 belt cutting machine. The solid industrial machine is completely made of stainless steel. It has been conceived caring specially about simple maintenance, easy and efficient cleaning and is, therefore, best suitable for professional applications.



## GS 20 Standard Highlights



### Exceptional cutting quality

Products are transported smoothly and held until point of cutting thus assuring a perfect cutting quality. Newly developed materials improve the operating life of the components and make replacement quick, easy and effective.



### Operation

The user-friendly electronic control panel allows digital in-motion cutting size adjustments. 100 individual, user-definable settings for the parameters knife / belt speed can be stored for a great variety of products.



### Cleaning and maintenance

As with all KRONEN machines, its excellent hygiene qualities are a major advantage: Inclined surfaces, stainless steel shaft seals and the elimination of screws in the cutting chamber door area, a seamless knife edge, etc. contribute to the improved performance of the GS 20 belt cutting machine. All machine parts as knives, guides, belts, belt tensioners etc. are quickly removable without any tools for cleaning. The solid industrial machine is completely made of stainless steel AISI 304. The basic principles for all KRONEN machines are:

- easy maintenance
- easy and efficient cleaning
- soft product guidance
- low operating expenses



### FDA approved

All parts that are in contact with food are made of stainless steel or FDA approved plastic, i.e. all of the machine is FDA approved. FDA approval is documented in manual supplied with machine.

# GS 20 Options & Accessories



### Mobile version

The GS20 belt cutter is available as mobile version (4 castors) for optimal application at different locations.



### Spraying nozzles for automatic cleaning

For most convenient and easy cleaning, the GS 20 belt cutter can be equipped with spraying nozzles (placed in the cutting chamber). This option is available with or without timer (water control is programmed or water control can be regulated by tap).



### Trimming & sorting table

We offer convenient and ergonomic trimming & sorting tables for 1 up to 16 and even more persons which are perfectly suited for adaption directly to the infeed belt of the GS 20 belt cutter. These tables are equipped with stepless belt speed adjustment, product guides, removable cutting boards, waste chute, etc. Various options and accessories are available such as hopper extensions, waste belts, crate supports, etc. – allowing improved yield and considerable increase in productivity!



### Conveyor belt

We offer various conveying belt systems for the efficient and smooth transport of your food products. Our product portfolio includes solutions for any given conveying demands from simple standard belt conveyors to complete conveying systems with electronic control. Due to the compact and modular construction the belts and other parts are quickly removable without any tools for cleaning.



### Cutting disc holder

This mobile cutting disc holder (4 castors) guarantees a safe storage of your knife discs as well as a quick access.

# Technical drawings & specifications

GS 20

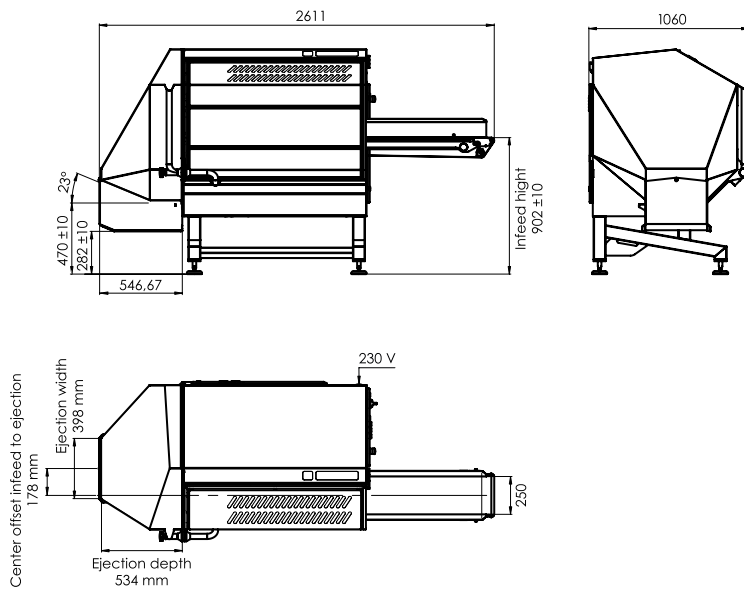

measures	
length	2600 mm
width	1050 mm
height	1490 mm
weight	530 kg
infeed / feeding height	905 mm
discharge / outfeed height	470 mm
belt width	250 mm
height of downholder	210 mm
conveyor speed	2,6-19 m/min
knife rotation speed	130-590 r/min
theoretical cutting thickness	1-50 mm
power	
total power	3 kW
voltage	1~230 V N/PE
frequency	50/60 Hz

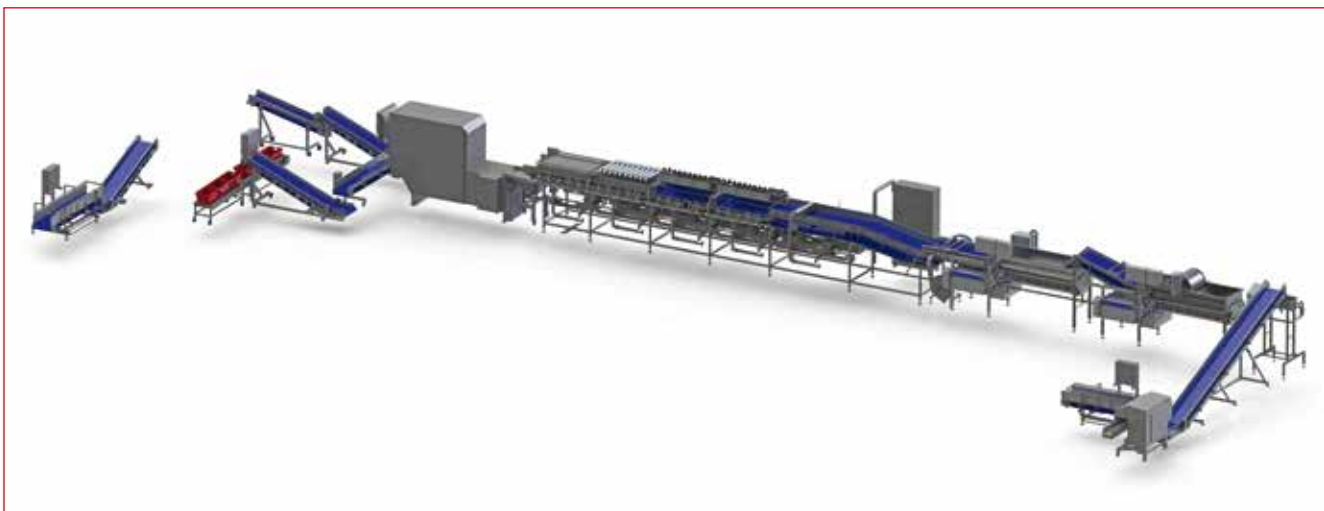

KRONEN creates customised solutions that work, such as complete processing lines for preparing, slicing, washing, drying, packaging as well as automatic conveying systems. The GS 20 cutting machine can be perfectly integrated into a professional production line. Smart solutions and convincing technology for the food processing industry!

# Accessories for belt cutting machine GS 20

- cutting possible
- cutting not possible
- depending on produce, consulting of KRONEN is recommended



vegetables

## 3-wing-knife



## Adjustable Cutting Disc 0-15 mm



## Special cabbage 10-blade-cutting-disc 1.3 mm, alu



## Special chives 3-blade-cutting-knife



## Special square-cut-disc 25 x 25 mm (2 cutting blocs) or 40 x 40 mm (1 cutting bloc)



## 6 blade strip cutting disc 3 x 3 mm or 5 x 5 mm



## Meat tearing knife



## Grating disc 3mm



	cucumber	aubergine	courgette	carrot	radish	cabbage turnip	potato	celeriac	onion	leek	pepper
3-wing-knife	●	○	○	○	○	○	○	○	○	●	●
Adjustable Cutting Disc 0-15 mm	●	●	●	●	●	●	●	○	●	●	●
Special cabbage 10-blade-cutting-disc 1.3 mm, alu	●	○	●	●	●	●	●	●	●	●	○
Special chives 3-blade-cutting-knife	●	●	●	●	●	●	●	○	●	●	●
Special square-cut-disc 25 x 25 mm (2 cutting blocs) or 40 x 40 mm (1 cutting bloc)	○	○	○	○	○	○	○	○	○	○	●
6 blade strip cutting disc 3 x 3 mm or 5 x 5 mm	●	●	●	●	●	●	●	●	●	○	●
Meat tearing knife	○	○	○	○	○	○	○	○	○	○	○
Grating disc 3mm	○	○	○	●	●	●	●	●	○	○	○

# Slices, dices, strips and much more

lettuce					cabbage			herbs				fish, meat, sausage								fruit	
endive	iceberg	chinese leaf	radicchio	chicory	cabbage	Savoy cabbage	curly kale	chives	parsley	basil	dill	herring	surimi	calamari	Lyoner sausage	salami	poultry	beef	vegan meat substitutes	pineapple	mango
●	●	●	●	●	○	○	●	●	○	●	●	●	●	●	●	○	●	○	○	●	●
●	●	●	●	●	●	●	●	●	●	●	●	●	○	●	●	●	●	○	○	●	●
○	○	○	○	○	●	●	○	○	●	○	○	○	○	○	○	●	○	○	○	○	●
●	●	●	●	●	●	●	●	●	●	●	●	●	○	●	●	●	●	○	○	●	●
●	●	●	●	●	●	●	●	○	○	○	○	○	○	○	○	○	○	○	○	○	○
○	○	○	○	○	●	○	○	○	○	○	○	○	○	○	○	○	○	○	○	○	○
○	○	○	○	○	○	○	○	○	○	○	○	○	○	○	○	○	●	●	●	○	○
○	○	○	○	○	○	○	○	○	○	○	○	○	○	○	○	○	○	○	○	○	○



## Product Range:

- **Belt cutting machines**  
GS 10-2, GS 20, GS 25V
- **Slice and wedge cutter**  
Tona S, Tona E, Tona S 180K
- **Special cutting and grid cutting machines**  
Tona Rapid, Tona Rapid 3D, Tona Rapid XL,  
Multicorer, Multislicer, TT 450
- **Cube and strip cutting machine** KUJ V
- **Multi purpose cutting machine** KSM 100
- **Cabbage cutting machine** CAP 68
- **Cabbage corer** KSB
- **Dicing, wedging and shaping machine**  
PGW, HGW
- **Vegetable and salad washing equipment**
- **Peeling machines**  
for citrus fruit, melons, apples, pineapples,  
potatoes, carrots, celery, etc.
- **Spin-dryers and de-watering systems**
- **Packaging machines**
- **Special machines**
- **Complete production lines**



We develop and manufacture single and special machines as well as complete processing lines for the food processing industry.

We successfully implement production processes for you by effectively combining single machines.

KRONEN - smart solutions and convincing technology for the food processing industry!



### KRONEN GmbH

Römerstraße 2a  
D-77964 Kehl am Rhein  
Telephone: +49 (0) 7854/96 46-0  
Telefax: +49 (0) 7854/96 46-50  
info@kronen.eu

An enterprise of  
Zillgith Beteiligungs GmbH

[www.kronen.eu](http://www.kronen.eu)