



RAFFAELLO

- Linea arrotondata priva di spigoli e viti in vista.
- Perno di scorrimento, cromato rettificato.
- Boccole di scorrimento autolubrificanti.
- Paracolpi su carrello in gomma vulcanizzata.
- Coperchio supporto vela smontabile.
- Parafetta in acciaio inox.
- Puleggia lama senza foro centrale per facilitare la pulizia.
- Movimento vela progressivo dei primi 3 mm di apertura, garantisce una maggiore precisione di regolazione taglio delle fette sottili.
- Anello di tenuta sull'albero vela per impedire che i liquidi percolino all'interno della macchina.
- Pratico smontaggio del coprilama
- Tutte le minuterie acciaio inox.
- 49,5 mm di distanza fra la lama e la testa.
- Copertura inferiore.
- Scheda elettronica commutabile 110-220-380 V monofase e trifase.
- Affilatoio con vaschetta inferiore di protezione.
- Estrattore lama di serie.
- Inclinazione lama 35°.

RAFFAELLO TOP

- Manopola alluminio.
- Piedini in alluminio telescopici con base in gomma.
- Pulsanti IP 67 in acciaio inox.
- Fornitura valigetta utensili.

RAFFAELLO

- Manopole plastica.
- Piedini in gomma.
- Pulsanti IP 67 in plastica

- *Rounded design, no sharp edges and visible screws.*
- *Chrome plated and ground slide rod.*
- *Self lubricating slide rod bushings.*
- *Vulcanized rubber stops on carriage.*
- *Removable support cover for thickness gauge plate.*
- *Stainless steel slice deflector.*
- *Blade pulley without centre hole to facilitate cleaning.*
- *Adjustable slicer table movement in the first 3 mm of opening, guarantees higher cutting precision of thin slices.*
- *Safety ring on table shaft to prevent liquids from seeping inside the machine.*
- *Easily removable blade cover*
- *Stainless steel screws and fittings.*
- *Enclosed and sealed belt pulley.*
- *49,5 mm distance between blade and motor.*
- *Bottom cover.*
- *Changeover electronic circuit 110-220-380 V single and three phase.*
- *Built in sharpening tool with bottom protection.*
- *Standard blade removal tool.*
- *35° blade inclination.*



RAFFAELLO 350 TOP



RAFFAELLO 350

RAFFAELLO TOP

- *Aluminium knob.*
- *Aluminium telescopic feet with rubber base.*
- *Stainless steel pushbuttons with IP67 protection rating.*
- *Maintenance tool kit.*

RAFFAELLO

- *Plastic knob.*
- *Rubber feet.*
- *Plastic pushbuttons with IP67 protection rating.*



1. Pratico smontaggio del coprilama
Easily removable blade cover



2. Mozzo lama chiuso, senza tirante paralama
Blade hub closed, without tie rod cover blade



3. Movimento vela progressivo, garantisce una maggiore precisione di regolazione taglio delle fette sottili
Adjustable slicer table movement, guarantees higher cutting precision of thin slices

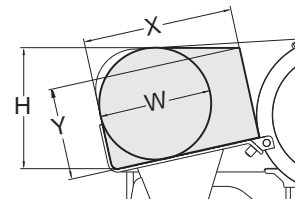
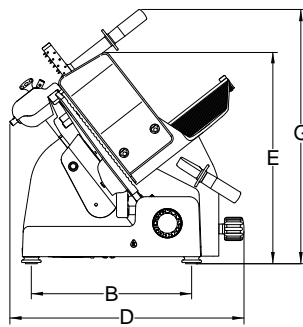
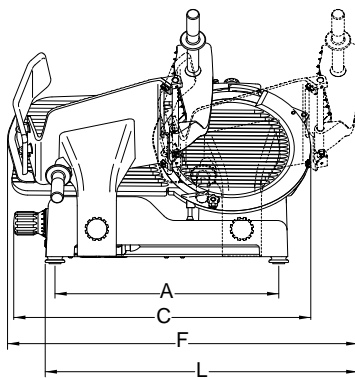

Ø Lama
Ø Blade
Ø Messer
Ø Lame
Motore
Motor
Moteur
Spessore taglio
Cut thickness
Schnittbreite
Épaisseur de coupe
Correa carrello
Run of carriage
Wagenschub
Course du charriot
Piatto
Hopper Wagen gösse
Plateau

	mm/inch.	watt/HP	mm	mm	mm	A	B	C	D	E	F	G	L	X	Y	H	W	Peso netto Net weight Nettogewicht Poids net	Dimensioni imballo Shipping Verpack abmessungen Dim. emballage	Peso lordo Gross weight Brutogewicht Poids brut
Raffaello 330	330/13"	275/0,37	23	355	330x307	513	340	690	560	475	840	595	725	307	205	260	240	37	760x640x700	46
Raffaello 350	350/14"	370/0,50	23	355	330x307	513	340	715	570	480	840	595	715	307	220	275	250	38	760x640x700	47
Raffaello 370	370/15"	370/0,50	23	355	330x307	513	340	735	580	470	840	590	715	307	230	285	260	39	760x640x700	48

Ø Cuchilla
Ø Lámia
Ø лезвие
刀片直径
Motor
Motor
Двигатель
电机
Espesor corte
Espessura corte
Толщина нарезки
切削厚度
Desplazamiento del carro
Escomintment carritino
Ход тележки
料斗行程
Piatto
Piatto
Лоток
料斗

Peso netto
Net weight
Nettogewicht
Poids net
Dimensioni imballo
Shipping
Verpack abmessungen
Dim. emballage
Peso lordo
Gross weight
Brutogewicht
Poids brut

Peso netto
Peso líquido
Вес нетто
净重
Dimensiones embalaje
Dimensões embalagem
Размеры упаковки
包装尺寸
Peso bruto
Peso bruto
Вес брутто
毛重