

PERLA



PERLA 220 A.I.-250

- Fusione in lega di alluminio anodizzato.
- Design classico.
- Silenzioso e robusto motore asincrono.
- Lama forgiata e temprata a forte spessore.
- Scorrimento carrello su boccole autolubrificanti.
- Affilatoio incorporato in fusione con doppio smeriglio di serie dal modello 220 A.I. in su.
- Disponibili lame teflonate o dentate.
- Inclinazione lama 25°.

- Anodized cast aluminium alloy.
- Classic design.
- Strong and silent-running asynchronous motor.
- Forged, hardened large thickness blades.
- Carriage running on self-lubricating bushes.
- Cast-in sharpener assembly.
- Cast-in sharpener is standard for all models bigger than 220 A.I.
- Teflon coated or toothed blades available on demand
- 25° blade inclination.

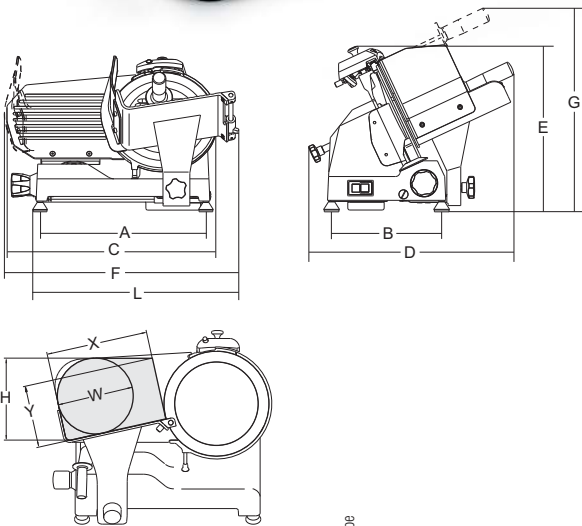

1. Paramano
Hand guard
2. Protezione inferiore
Underside motor protection plate
3. Affilatoio scorporato 195-220
Without built-in sharpener 195-220

	Ø Lama Ø Blade Ø Messer Ø Lame	Spessore taglio Cut thickness Cuttlaberte Schnittlaberte Epaisseur de coupe	Corso carrello Run of carriage Wagenschub Course du chariot	Piatto Hopper Wagen grösse Plateau	A	B	C	D	E	F	G	L	X	Y	H	W	Peso netto Net weight Nettogewicht Pois net	Dimensioni imballo Shipping Verpack abmessungen Dim. emballage	Peso lordo Gross weight Bruttogewicht Poids brut	
	mm/inch.	watt/Hp	mm	mm	mm	mm	mm	mm	mm	mm	mm	mm	mm	mm	mm	mm	kg	mm	kg	
Perla 195	195/8"	110/0,15	15	162	185x165	310	220	375	355	300	385	360	370	140	110	135	120	10,5	430x400 x370	12
Perla 220	220/9"	145/0,20	15	245	200x220	380	250	440	390	330	470	400	450	200	130	145	140	13	600x500 x420	15
Perla 220 A.I.	220/9"	145/0,20	15	245	200x220	380	250	440	390	350	470	400	450	200	140	160	155	13,5	600x500 x420	15,5
Perla 250 C	250/10"	145/0,20	15	240	230x230	380	250	480	420	360	520	410	435	185	165	180	180	14	600x500 x420	16
Perla 250	250/10"	145/0,20	15	235	220x225	412	255	480	410	360	515	455	505	210	170	190	180	15,5	600x500 x420	17,5



PERLA 195 - 220