

AUTOMATIC CLIPPER WITH ONE OR WITH TWO CYLINDER HEADS



This machine has been designed to carry out the sealing of encased products through the use of aluminium clips.

CLIP 2T :

Once the salumi is encased, the operator inserts the leftover casing into the slot of the right cylinder head and by use of a peddle, the first clip is applied;

then the other leftover casing, that is still attached to the coil, is inserted into the slot of the left cylinder head and into the vice.

The vice carries out the mechanical traction of the casing that is necessary to remove residual air in the product and compacts at the same time.

At this stage, the application of a second clip takes place, again, by using the peddle.

The blade of the cylinder head automatically cuts the skin separating it from the rest of the coil and the product is packaged.

CLIP 1T :

Once the salumi is encased, the operator inserts the leftover casing into the slot of the right cylinder head and by use of a peddle, the first clip is applied; the piece is, then, rotated 180° and the other leftover casing that is still attached to the coil is then inserted into the slot and the vice.

The vice carries out the mechanical traction of the casing that is necessary to remove residual air in the product and compacts at the same time.

At this stage, the application of a second clip takes place, again, by using the peddle.

The blade of the cylinder head automatically cuts the casing separating it from the rest of the coil and the product is packaged.

The vice is a new concept that guarantees the best results of the product and doesn't need any replacement or maintenance.

With this new system, as well as the execution of perfect clipping for packaged products, one obtains complete use of the skin, consequently minimising waste saving materials.

The machine is made entirely out of stainless steel 304.

The working is completely pneumatic.

TECHNICAL DATA

Input pressure:	7 Bar
Air consumption CLIP 1T:	130 NI/min
Air consumption: CLIP 2T	150 NI/min



im

INOX MECCANICA

TECHNOLOGY FOR THE FOOD PROCESSING INDUSTRY

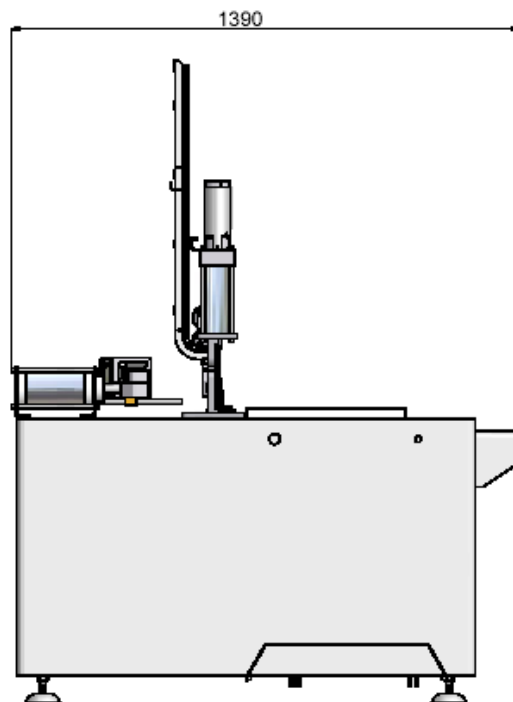
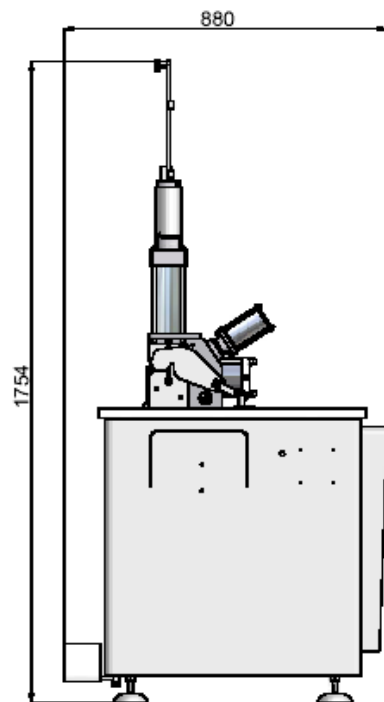
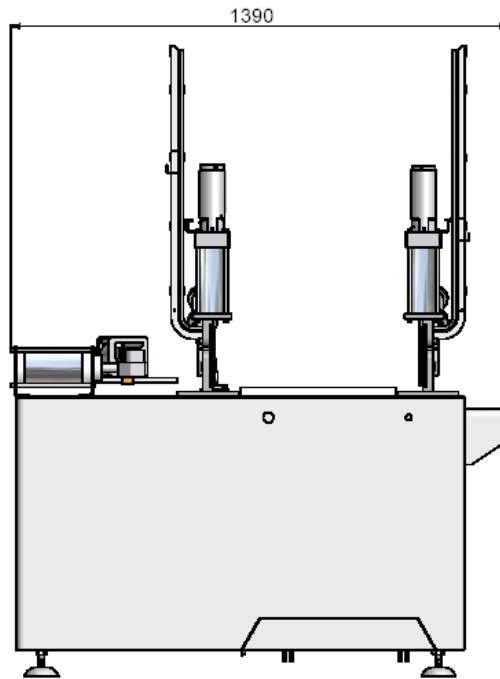
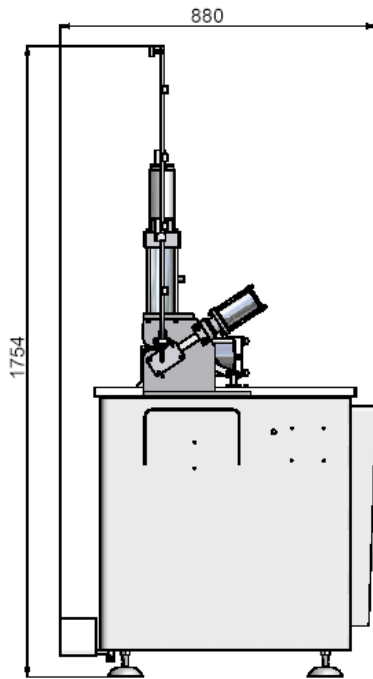

INOX MECCANICA s.r.l.
Strada Solarolo, 20/B-C-D - 46040 Solarolo di Goito (Mantova) Italy
Tel. +39-0376.60.82.82 - Fax +39-0376.60.81.80
E-mail: inoxmec@tin.it

www.inoxmeccanica.it