



IS 8-16 X - IS 12 VX



Insaccatrici manuali manual sausage stuffers



IS 8-16 X

- Corpo e cilindro in acciaio inox AISI 304.
- Robusto cilindro raggiato e con doppia saldatura sul fondello.
- Pistone in nylon alimentare con valvola di sfiato aria.
- Scatola ingranaggi in acciaio zincato.
- Ingranaggi in acciaio temperato e rettificato.
- Scorrimento ingranaggi su 4 cuscinetti ermetici.
- Sistema riduzione a doppia velocità.
- In dotazione: 3 imbusti in nylon alimentare bianco. Morsetto fissaggio.

Opzionale: Cremagliera in acciaio inox.

- AISI 304 S/S body and cylinder.
- Sturdy cylinder with double welding on the bottom plate.
- Nylon pistons with air exhaust valve.
- Galvanized steel gear box.
- Ground and tempered steel gears.
- Gears sliding on 4 sealed bearings.
- 2 speed gear reducer.
- Standard: 3 nylon filling tubes. Fixing clamp.

Optional: Stainless steel rack.



IS 12 VX



1. Porta imbusti
Holder funnels

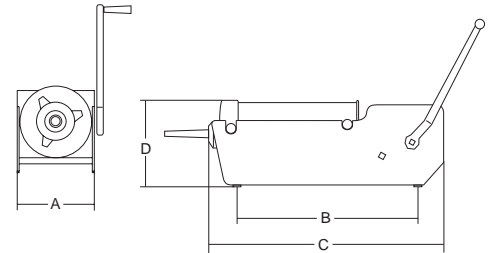
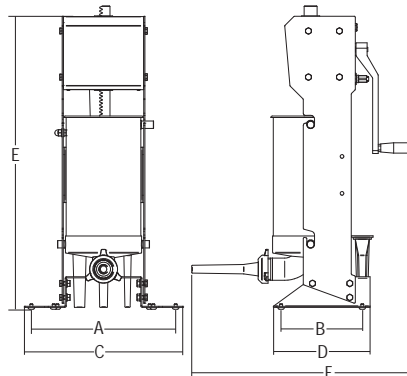

Capacità cilindro
Cylinder capacity
Inhalt Zylinder
Capacité Cylindre

Lunghezza cilindro
Cylinder length
Zylinder laenge
Longeur cylindre

Diametro cilindro
Cylinder diameter
Zylinder Durchmesser
Diamètre cylindre

Corsa pistone
Piston stroke
Kolben hob
Course piston

Imbusti in dotazione \varnothing int.
 \varnothing Serie exhaust funnels
 \varnothing Zusatzliche Trichter
 \varnothing Entnomm in dotation

A B C D E F

Peso netto
Net weight
Nettogewicht
Poids net

Dimensioni imballo
Shipping
Verpack abmessungen
Dim. emballage

Peso lordo
Gross weight
Bruttogewicht
Poids brut

	lt	mm	\varnothing mm	mm	\varnothing mm	mm	mm	mm	mm	mm	mm	Kg	mm	kg
IS 8 X	8	370	165	420	10-18-25	200	430	660	220	-	-	19	730x260x250	20
IS 16 X	16	500	200	560	10-18-25	240	575	820	250	-	-	23,5	890x310x280	24,5
IS 12 VX	12	380	200	420	10-18-25	400	190	435	250	794	602	24	890x310x280	26

Capacidad cilindro
Capacidade cilindro
Емкость цилиндра

Longitud cilindro
Comprimento cilindro
Длина цилиндра

Diametro cilindro
Диаметр цилиндра

Trayecto pistón
Curso pistón
Шар прохода
活塞行程

Embudos en dotación \varnothing int.
 \varnothing Funis em dotação
Внутр. \varnothing прилагаемых воронков
直径不同的系列漏斗

A B C D E F

Peso netto
Peso líquido
Вес нетто
淨重

Dimensiones embalaje
Dimensões embalagem
Размеры упаковки
包裝尺寸

Peso bruto
Peso brutto
Вес брутто
毛重



IS 12 VX

2. Ribaltamento cilindro
Cylinder overturn



IS 8-16 X



IS 8-16 X

3. Estrema facilità di pulizia
Very easy to clean