

# FCA 80

## Automatic Double-Clipper



innovative · reliable · leading

**poly-clip**<sup>®</sup>  
SYSTEM

# FCA 80

- For a range of calibres from 38 to 160 mm and up to 125 cycles per minute
- Robust and of stainless steel design for highest reliability and a long service life
- Maximum productivity with basic oriented operation

## Applications

The Automatic Double-Clipper FCA 80 closes all fibrous and collagen casings up to a calibre of 120 mm (depending on the material thickness) and plastic casings up to 160 mm. It processes R-Clips 15 and 18 up to clip size 18-14. The model FCA 80 R-ID processes the clip series M, L and XL. High flexibility is achieved by the possible spreadings 26, 30, 36 or 44 mm.

## Advantages

- Easy clipping optimized to the essentials
- Short sausage shoulders, uniform pleating and clean sausage tails due to the linear vertical voiding separator
- Highest productivity adjustable in three speed levels
- Air-free slack filling of moulded products by overspreading, total spreading up to 100 mm, manually adjustable
- Robustness and long service life guaranteed by use of stainless steel
- Ergonomic and functional controls for product-specific settings
- Comfortable external adjustment of the separator hole
- Electronic hand-wheel for adjustments, clip loading position, clip pressure and parameter settings
- Additional safety for the operator by two-handed triggering of the first clip
- Adjustable conveyor belt speed for products true to the calibre



Powerful for large calibres

- Simple, ergonomic handling for reloading of casing, without swing-out of the clip head
- Easy to manoeuvre with two lockable and two fixed wheels
- Low noise level
- Stainless steel provides resistance to aggressive cleaning solutions
- Smooth surfaces, large openings and flaps make for easy cleaning
- Completely enclosed switch cabinet
- Centralized lubrication strip for easy maintenance
- Extremely compact design for easy serviceability with few wear parts easily accessible

## Optional equipment

- Special machine version for rings with adapted front flap and double-conveyor belt 700 mm
- String dispenser for rings
- Conveyor and roller extension, variants to suit products
- Automatic looper GSA 20
- Comfort setting for spreading and overspreading
- Swivelling twin turret – reload casing without swing-out of the clip head
- Brake assistant – semi-automatic casing brake holder for fastest reloading of casings
- Pneumatic casing brake (dry sausage brake) fixed

Automatic looper GSA 20 – easy reload of loops



The alternative to the filling horn – FCA 80 with twin turret



- Length portioning by optical sensor
- Filler coupling with ball joint
- Single clip feature
- Casing end switch
- Clip coding

### FCA 80 R-ID additionally:

- Incorrect settings are avoided by detection of the clip size and die
- Auto-Stop System Clip – sensor monitoring the end of clip supply on the reel
- Tool free quick-change system of the die

### Function and operation

The Automatic Double-Clipper FCA 80 is connected mechanically and electrically to the stuffer. The portions are fed in precisely to the nearest gram and closed by a clip as single portions or chains. The FCA 80 with its controller board is driven by a servo frequency converter. The clear control panel includes function keys for the counters knife, loop, label and single clip feature. The holder of the casing brake is also suitable for the optional pneumatic casing brake. Reload of casing is simple and comfortable, without swing-out of the clip head.

### Combinability

**ES 5000** – labelling system for marking and traceability



FCA 80 with adjusted front flap and double-conveyor belt specifically for rings

### Clip System Solutions

The complete system of clipping machine, clips and loops from one source ensures efficient, trouble-free production. The original clips from Poly-clip System guarantee top quality. The manufacture is subject to strictest quality standards, is certified to ISO 22000:2005 and ISO 9001:2008 and tuned precisely to the production process. The patented, food-proof, safety coating using Poly-clip SAFE-COAT technology, certified by the SGS INSTITUT FRESENIUS organization, ensures trouble-free production and a no-worry product warranty. Poly-clip System is the world's leading provider of Clip System Solutions.

Product outlet with adjustable double-conveyor belt



Marking with labels that are printed inline and clipped.



Maximum product variety with ease of use with the FCA 80



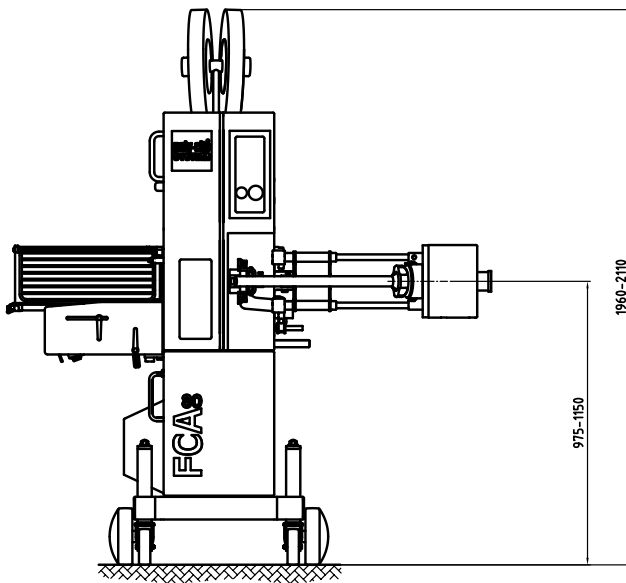

Front view

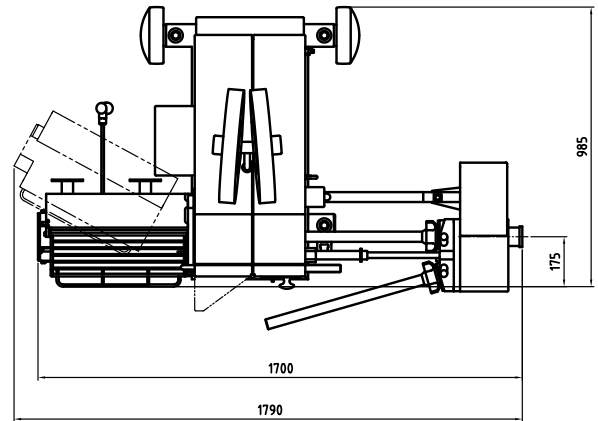

Length of filling horn 600

Top view

Width:	1,700-1,790 mm
Depth:	985 mm
Height:	1,960-2,110 mm
Weight:	460 kg
Three-phase current connection:	200-230 VAC, 380-460 VAC, 50/60 Hz
Power input:	4 kW
Fuse connection:	16 A
Compressed air:	5-7 bar/0.5-0.7 MPa
Air consumption:	2.5 NL/cycle

R-Clip:	15, 18
R-ID Clip:	M, L, XL
Spreading:	26, 30, 36, 44 mm
Incl. overspreading up to:	100 mm